ER-5200/40/15



Operation and Program Manual

All specifications are subject to change without notice

Precaution Statements

Follow these safety, servicing and ESD precautions to prevent damage and to protect against potential hazards such as electrical shock.

1-1 Safety Precautions

1. Be sure that all built-in protective devices are replaced. Restore any missing protective shields.
2. When reinstalling the chassis and its assemblies, be sure to restore all protective devices, including nonmetallic control knobs and compartment covers.
3. Make sure there are no cabinet openings through which people - particularly children - might insert fingers and contact dangerous voltages. Such openings include excessively wide cabinet ventilation slots and improperly fitted covers and drawers.
4. Design Alteration Warning:
Never alter or add to the mechanical or electrical design of the SECR. Unauthorized alterations might create a safety hazard. Also, any design changes or additions will void the manufacturer's warranty.
5. Components, parts and wiring that appear to have overheated or that are otherwise damaged should be replaced with parts that meet the original specifications. Always determine the cause of damage or over- heating, and correct any potential hazards.
6. Observe the original lead dress, especially near the following areas : sharp edges, and especially the AC and high voltage supplies. Always inspect for pinched, out-of-place, or frayed wiring. Do not change the spacing between comp-onents and the printed circuit board. Check the AC power cord for damage. Make sure that leads and components do not touch thermally hot parts.
7. Product Safety Notice:
Some electrical and mechanical parts have special safety-related characteristics which might not be obvious from visual inspection. These safety features and the protection they give might be lost if the replacement component differs from the original - even if the replacement is rated for higher voltage, wattage, etc.
Components that are critical for safety are indicated in the circuit diagram by shading, () or (). Use replacement components that have the same ratings, especially for flame resistance and dielectric strength specifications. A replacement part that does not have the same safety characteristics as the original might create shock, fire or other hazards.

CAUTION

Danger of explosion if battery is incorrectly replaced.

Replace only with the same or equivalent type recommended by the manufacturer.

Dispose used batteries according to the manufacturer's instructions.

ATTENTION

Il y a danger d'explosion s'il y a un remplacement incorrect de la batterie.

Remplacer uniquement avec une batterie du même type ou d'un type équivalent recommandé par le constructeur.

Mettre au rebut les batteries usagées conformément aux instructions du fabricant.

1-2 Servicing Precautions

WARNING: First read the-Safety Precautions-section of this manual. If some unforeseen circumstance creates a conflict between the servicing and safety precautions, always follow the safety precautions.

WARNING: An electrolytic capacitor installed with the wrong polarity might explode.

1. Servicing precautions are printed on the cabinet. Follow them.
2. Always unplug the units AC power cord from the AC power source before attempting to:
 - (a) Remove or reinstall any component or assembly
 - (b) Disconnect an electrical plug or connector
 - (c) Connect a test component in parallel with an electrolytic capacitor
3. Some components are raised above the printed circuit board for safety. An insulation tube or tape is sometimes used. The internal wiring is sometimes clamped to prevent contact with thermally hot components. Reinstall all such elements to their original position.
4. After servicing, always check that the screws, components and wiring have been correctly reinstalled. Make sure that the portion around the serviced part has not been damaged.
5. Check the insulation between the blades of the AC plug and accessible conductive parts (examples : metal panels and input terminals).
6. Insulation Checking Procedure:
Disconnect the power cord from the AC source and turn the power switch ON. Connect an insulation resistance meter (500V) to the blades of AC plug.
The insulation resistance between each blade of the AC plug and accessible conductive parts (see above) should be greater than 1 megohm.
7. Never defeat any of the B+ voltage interlocks. Do not apply AC power to the unit (or any of its assemblies) unless all solid-state heat sinks are correctly installed.
8. Always connect an instrument's ground lead to the instrument chassis ground before connecting the positive lead ; always remove the instrument's ground lead last.

1-3 Precautions for Electrostatically Sensitive Devices (ESDs)

1. Some semiconductor (solid state) devices are easily damaged by static electricity. Such components are called Electrostatically Sensitive Devices (ESDs); examples include integrated circuits and some field-effect transistors. The following techniques will reduce the occurrence of component damage caused by static electricity.
2. Immediately before handling any semiconductor components or assemblies, drain the electrostatic charge from your body by touching a known earth ground. Alternatively, wear a discharging wrist-strap device. (Be sure to remove it prior to applying power - this is an electric shock precaution.)
3. After removing an ESD-equipped assembly, place it on a conductive surface such as aluminum foil to prevent accumulation of electrostatic charge.
4. Do not use freon-propelled chemicals. These can generate electrical charges that damage ESDs.
5. Use only a grounded-tip soldering iron when soldering or unsoldering ESDs.
6. Use only an anti-static solder removal device. Many solder removal devices are not rated as anti-static; these can accumulate sufficient electrical charge to damage ESDs.
7. Do not remove a replacement ESD from its protective package until you are ready to install it. Most replacement ESDs are packaged with leads that are electrically shorted together by conductive foam, aluminum foil or other conductive materials.
8. Immediately before removing the protective material from the leads of a replacement ESD, touch the protective material to the chassis or circuit assembly into which the device will be installed.
9. Minimize body motions when handling unpackaged replacement ESDs. Motions such as brushing clothes together, or lifting a foot from a carpeted floor can generate enough static electricity to damage an ESD.

Contents

Getting Started	1
About the <i>ER-5200</i> Series	1
Unpacking.....	2
Installing the Paper	2
Basic Features and Functions	6
Standard Hardware	6
Optional Hardware	6
Software Features	6
Display	7
Control Lock	11
Keyboards.....	12
Operating Instructions	15
Function Key Descriptions	15
Clerk Sign-On/Sign-Off	19
Direct Sign-On	19
Coded Sign-On.....	19
Receipt On and Off.....	20
Item Registrations.....	21
Open Keyboard PLU Entry	22
Preset Price Keyboard PLU.....	22
Keyboard PLU Repeat Entry.....	23
Keyboard PLU Multiplication.....	24
Keyboard PLU Multiplication with Decimal Point.....	25
Split Pricing (Keyboard PLU).....	26
Single Item Keyboard PLU	27
Open Code Entry PLU	28
Preset Price Code Entry PLU	28
Code Entry PLU Multiplication	29
Code Entry PLU Multiplication with Decimal Point	30
Split Pricing Code Entry PLU	30
Modifier Key	31
Price Level Key.....	32
Promo	33
Waste.....	34
Shifting or Exempting Tax	35
Shifting Tax.....	35
Exempting Tax	36
Percent Key Operations	38
Preset Percent Discount on an Item.....	38
Enter a Percent Discount on an Item	39
Percent on Sale Total.....	39
Coupon on Sale (Vendor Coupon).....	40

Coupon on Item (Store Coupon)	41
Return Merchandise Registrations	42
Voids and Corrections	43
Error Correction (Void Last Item)	43
Void Previous Item	43
Cancel	44
Void Position Operations	44
No Sale Operations	45
Open Drawer	45
Non Add Number	45
Received On Account Operations	46
Paid Out Operations	47
Subtotaling a Sale	48
Eat In/Take Out/Drive Thru Sales	48
Totaling and Tendering	49
Totaling a Cash Sale	49
Totaling a Check Sale	49
Tendering a Cash Sale	50
Tendering a Check Sale	50
Totaling a Charge Sale	51
Tendering a Charge Sale	52
Check Cashing	53
Split Tender	54
Post Tender	55
Food Stamp Sales	56
Currency Conversion	57
Table Management and Clerk Interrupt Operations	58
Overview	58
Posting Balances Manually	59
Soft Check	61
Hard Check	64
Direct Scale Entry	67
Automatic Scale Entry	68
Tare Weight Entry	68
Manual Tare Weight Entry	69
Manual Weight Entry	70

X Mode 71

Introduction	71
X Reports	72
Running a Report - General Instructions	72
Report Table	73
Cash Declaration	74

Service Mode Programming 75

Overview	75
Memory Allocation Scan	76
Pc Online Mode	76
Pc Memory Allocation	77
Clear Total	78
Clear Grand Total	78
Clear PLU File	78
Eprom Information	78

Function Key Assignment Programming	79
Function Key Codes	80
RS232C Port 1/RS232C Port 2 Options	81

Program Mode Programming 83

Default Programming	83
Descriptor Programming Methods.....	83
Program Overlay Method	84
Descriptor Code Method	85
Tax Programming	86
Straight Percentage Tax Rate Programming	86
PLU Programming.....	88
Program 100 - PLU Status Programming.....	89
Program 110 - PLU Auto Tare Programming	92
Program 150 - PLU Group Assignment	93
Program 200 - PLU Price/HALO Programming	94
Program 250 - PLU Stock Amount Programming	95
Program 300 - PLU Description Programming	96
Program 350 - PLU Link Programming.....	97
Program 400 - PLU Delete Programming	98
Program 450 - PLU MIX & MATCH Programming	99
System Option Programming.....	100
System Option Table	101
Print Option Programming	104
Print Option Table.....	105
Function Key Programming	109
Program 70 - Function Key Options	110
Program 80 - Function Key Descriptor	111
Program 90 - Function Key HALO.....	112
ADD CHECK.....	113
CANCEL.....	114
CASH	115
CHARGE1-8	116
CHECK	117
CHECK CASHING.....	118
CHECK ENDORSEMENT.....	119
CHECK #	120
CURRENCY CONVERSION	121
DRIVE THRU / EAT IN / TAKE OUT	122
ERROR CORRECT	123
F/S SUB.....	123
F/S TEND.....	124
GUEST	125
LEVEL1-2.....	125
#/NS.....	126
RETURN.....	127
MODIFIER 1-5	128
PAYMENT.....	129
PBAL.....	129
PROMO.....	130
PAID OUT1-3	131
PRINT CHECK.....	132
RECD ON ACCT1-3.....	133
SCALE	134

SERVICE	135
SUBTOTAL	136
TABLE	136
TARE.....	137
TAX EXEMPT.....	138
TIP	139
VALIDATE.....	140
VOID	141
WASTE	142
%1- %5	143
Clerk Programming.....	145
Program 800 - Secret Code Programming.....	146
Program 801 - Drawer Assignment & Training Clerk	147
Program 810 – Clerk Description Programming	148
Mix & Match Programming.....	149
Program 600 - Trip Level Programming	150
Program 601 - Price Programming	150
Program 610 - Mix & Match Description Programming.....	151
Group Programming	152
Miscellaneous Programming	154
Macro Key Sequence Programming.....	154
Logo Description Programming	155
NLU Code Number Programming	162
Cash-In-Drawer Limit Programming	163
Check Change Limit Programming.....	164
Date and Time Programming.....	165
Scale Tare Weight Programming	166
Machine Number Programming	167
Program Scans	168

Getting Started

About the *ER-5200* Series

The *ER-5200* Series is offered in three different versions.

- The *ER-5200* features a flat 160 position keyboard with 117 NLU keys. Because it offers protection from spills, this keyboard works best in restaurants, food service shops, or convenience stores where food is served.
- The *ER-5240* features a 90 position keyboard with traditional raised keys. This keyboard will accommodate up to 40 NLU keys and works best in retail stores, or shops where it is not necessary to place a large number of preset item keys on the keyboard.
- The *ER-5215* features a 60 position keyboard with traditional raised keys. This keyboard will accommodate up to 15 NLU keys and works best in retail stores, or shops where it is not necessary to place a large number of preset item keys on the keyboard.

This manual includes instructions for three models. The keyboard is the only significant difference between the three models. All other features are the same, unless otherwise noted.

Unpacking

1. Unpack and unwrap the cash register.
2. Located in the packing are the following items:
 - 1 roll of paper and paper spindle,
 - 2 sets of control keys,
 - Operation and Program Manual,
3. Remove the cardboard protectors from the cash drawer.
4. Plug the register into a grounded outlet (three prong), insert a control key and turn the key to the **REG** control lock position.

Installing the Paper

1. Remove the printer cover.

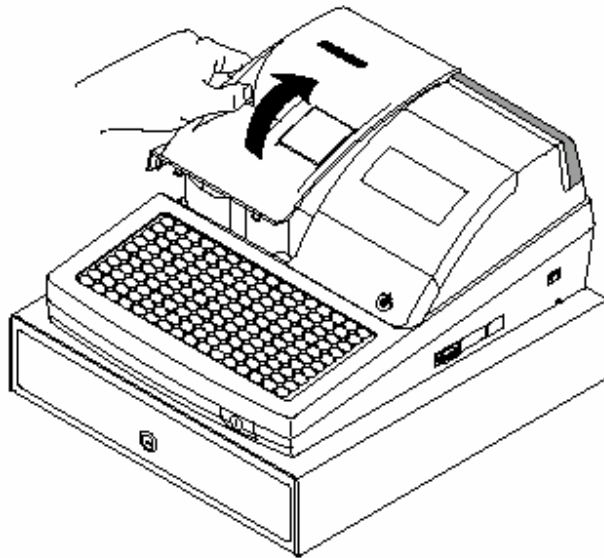

2. Push the blue cap lever and then lift up to open the paper cover.

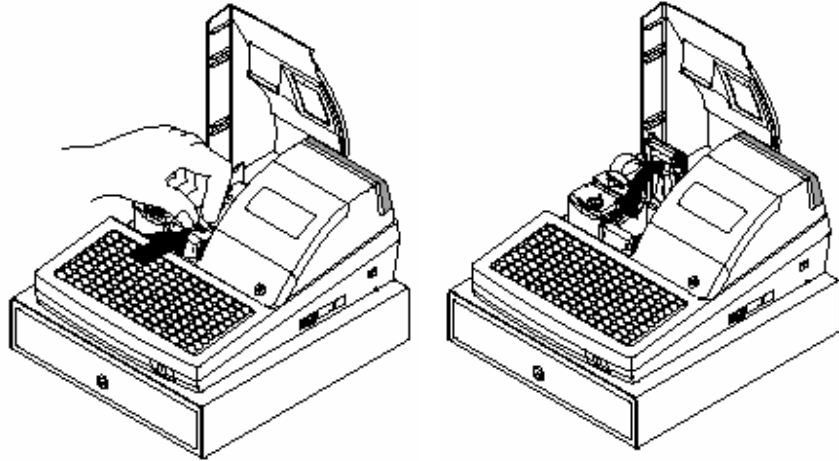

3. Ensure that the paper is being fed from the bottom of the roll.

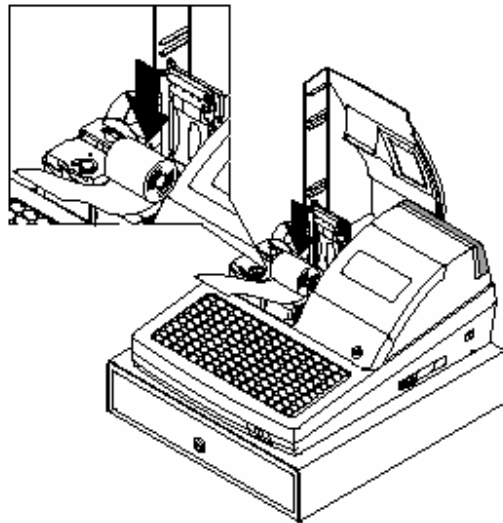

4. Put the the leading edge of the paper over the printer
5. Close the paper cover slowly until it locks firmly

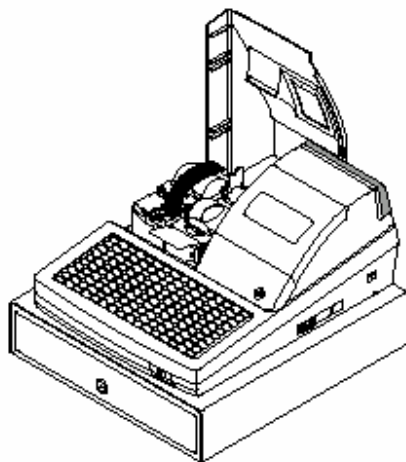

6. Passing the leading edge of the paper through the cutter slot. Tear off the excess paper. Replace the printer cover.

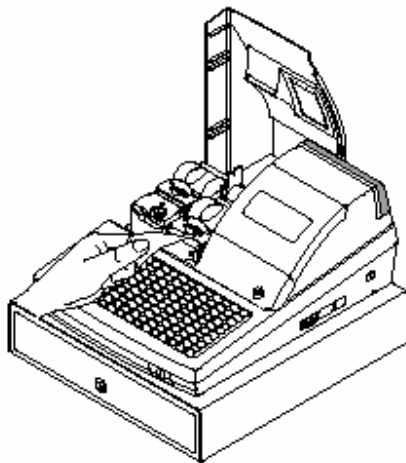

7. If you wish to use the printer to print a sales journal, insert the paper into the paper take-up spool. Wind the paper two or three turns around the spool shaft and install the spool in the mount.

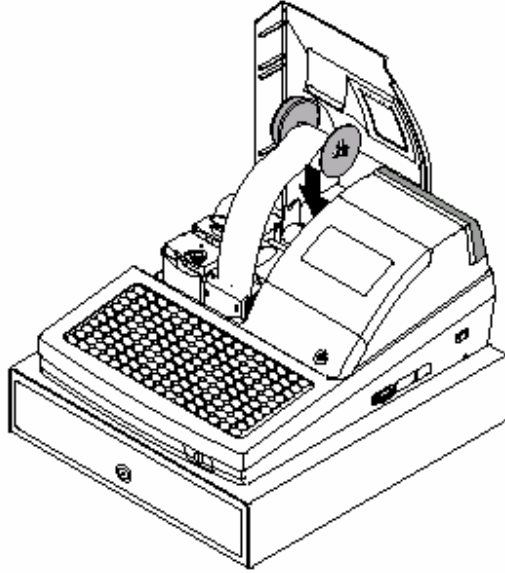

Basic Features and Functions

Standard Hardware

- Ten position front and rear displays with a rear pop up display standard.
- 160(ER-5200),90(ER-5240),60(ER-5215) position keyboard.
- 2 station Thermal 32-column printer with drop-and-print mechanism.
- Sturdy Metal Cash Drawer with removable 5 Bill/5 Coin or 4Bill/8 Coindrawer insert.
- 7-position control lock.
- Standard customer pole display.
- Communications ports: 2 RS232C.

Optional Hardware

- Load cell scale.
- Kitchen printer.
- Bar code scanner.
- Coin changer.
- Pole Display.
- Real clerk keys and lock assembly for 15 clerks.

Software Features

- Up to 2 price levels for each PLU.
- Up to 5 PLU modifier keys.
- 1000 Price Look Ups (PLUs) for open or preset item registration. For direct registrations, up to 117 PLUs are on the *ER-5200* keyboard; up to 40 PLUs are on the *ER-5240* keyboard, up to 15 PLUs are on the *ER-5215* keyboard.
- 18 character programmable descriptors for PLUs and functions.
- Up to 99 PLU Group totals.
- Up to 99 clerks with separate report totals.

Display

The *ER-5200/40/15* comes with a ten position front display. Annotations on the display window include:

- **RPT**, where a counter appears when the same item is multiplied or repeated.
- The **AMOUNT** area shows the amount, i.e. price, subtotal or total.
- **RCPT OFF** indicates when the receipt is turned off.
- The **VOID** symbol illuminates during Void operations.
- The **SHIFT** symbol illuminates during Tax Shift operations
- The **CLERK** segment remains illuminated as long as a clerk is signed on.

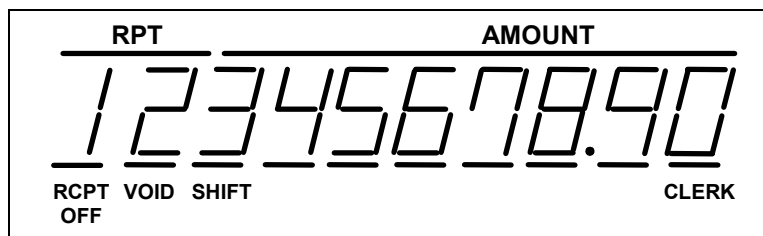

The front display offers supplemental descriptors which appear in the first two display positions (as shown). These descriptors help the operator by supplying additional information while operating the register, and may be accompanied by an error tone.

Supplemental descriptors include:

Change Due

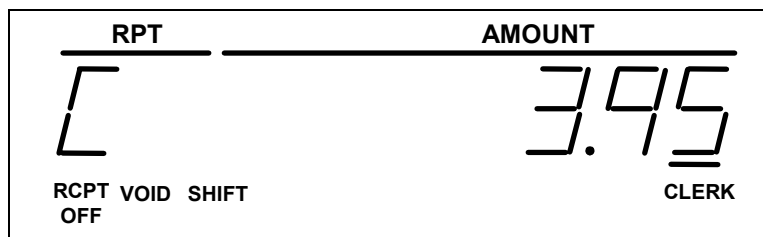

Negative Entry

RPT	AMOUNT
	-0.75
RCPT OFF	VOID SHIFT CLERK

Subtotal

RPT	AMOUNT
Sub	12.50
RCPT OFF	VOID SHIFT CLERK

Numbered Error Conditions

RPT	AMOUNT
E01	0.00
RCPT OFF	VOID SHIFT CLERK

E0	SEQUENCE ERROR
E1	PLU NO DATA
E2	CLERK ERROR
E3	AMOUNT COUNT OVER
E4	LAN TRAN
E5	COMMUNICATION ERROR
E6	TIME AND DATE
E7	LIMIT OVER
E8	INACTIVE
E9	XMODE ONLY
E10	NONADD
E11	ADDCHECK ERROR
E12	CONDIMENT ERROR
E13	REQ. EAT IN
E14	REQ. STOCK
E15	REQ.DRAWER
E16	REQ.GUEST
E17	SCALE
E18	CLERK NOT MATCH
E19	COMPULSORY TARE
E20	REQ.DECLARATION
E21	OFF LINE
E22	REQ.ENDORSEMENT
E23	CONSOL OVER
E24	REQ.SUBTOTAL
E25	PROMO ERROR
E26	CHECK OPEN
E27	REQ. PASSWORD
E28	NO VOID PLU
E29	232C SETUP ERROR
E30	REQ.PRESET VALUE
E31	REQ. OPEN VALUE
E32	REQ. AMOUNT
E33	REQ. PAYMENT
E34	INVALID FUNCTION

E35	REQ. TABLE
E36	REQ. PBAL
E37	REQ.CHECK #
E38	ONLY ONE TABLE
E39	REQ. VALID
PER	RECEIPT PRINTER PAPER END
PEJ	JOURNAL PRINTER PAPER END
PΠR	RECEIPT PRINTER PAPER NEAR-END
PΠJ	JOURNAL PRINTER PAPER NEAR-END
PCO	PRINTER COVER OPEN
ACJ	AUTO CUTTER PAPER JAM
PFP	SYSTEM ERROR (If this problem occurs, call the service engineer.)

Control Lock

The control lock has 7 positions, accessed with 5 keys. Each ECR is shipped with two full sets of keys.

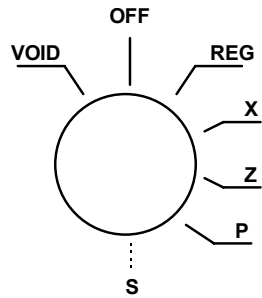

- VOID** Use to void (correct) items outside of a sale.
- OFF** The register is inoperable.
- REG** Use for normal registrations.
- X** Use to read register reports.
- Z** Use to read register reports and reset totals to zero.
- P** Use to program the register.
- S** The S position is a hidden position reserved for dealer access.

Before performing any operations in Register Mode a clerk must be signed on. See “Clerk Sign-On/Sign-Off” for a description of clerk operations.

Control Keys

The *ER-5200/40/15* includes two sets of keys that may be used to access the following control lock positions.

Key	Positions Accessible
REG	OFF, REG
VOID	VOID, OFF, REG, X
Z	VOID, OFF, REG, X, Z
P	VOID, OFF, REG, X, Z, P
C	ALL POSITIONS

Note: Keys may be removed from the control lock in the OFF or REG positions.

Keyboards

ER-5200 Keyboard

The *ER-5200* keyboard includes 160 key positions with the default legends and key assignments as shown below. The keyboard legend sheet can be replaced by lifting the protective plastic cover.

Programmable key locations are shown with a bold border.

RECT FEED	DETL FEED	RCPT ON/OFF										TAX 1	ADD CHECK 6	PAID OUT 12	CLERK 18
												% 1 2	CHECK # 7	RECD ACCT 13	CONV1 19
												% 2 3	SERVIC E 8	VOID 14	CONV2 20
												% 3 4	ERROR CORR 9	RETURN 15	EAT IN 21
												VALID 5	#/NS 10	CANCEL 16	TAKE OUT 22
												CLEAR	PLU 11	X/TIME 17	CHARG E2 23
												7	8	9	CHARG E1 24
												4	5	6	CHECK 25
												1	2	3	SBTL 26
												0	00	.	CASH 27

ER-5240 Keyboard

The ER-5240 keyboard is shown below with the default legends and key assignments.

This configuration has 40 keyboard NLU locations. Programmable key locations are shown with a bold border.

RECT FEED	DETL FEED	RCPT ON/OFF	#NS 10	TAX 11	CHECK # 13	SERVIC E 14	RECD ACCT 15	PAID OUT 16	PRINT CHECK 17	ADD CHECK 18	CONV1 19	CONV2 20	EAT IN 21	CLERK 24
ERROR CORR 1	P L U 6	CLEAR		X/TIME 12	5	10	15	20	25	30	35	40	TAKE OUT 22	CHARG E2 25
VOID 2		7	8	9	4	9	14	19	24	29	34	39	DRIVE THRU 23	CHARG E1 26
%1 3	RETURN 7	4	5	6	3	8	13	18	23	28	33	38	CHECK 27	
%2 4	CANCEL 8	1	2	3	2	7	12	17	22	27	32	37	SBTL 28	
%3 5	VALID 9	0	00	.	1	6	11	16	21	26	31	36	CASH 29	

ER-5215 Keyboard

The *ER-5215* keyboard is shown below with the default legends and key assignments.

This configuration has 15 keyboard NLU locations. Programmable key locations are shown with a bold border.

RECT FEED	DETL FEED	RCPT ON/OFF	PLU	RECD ACCT	PAID OUT	CHECK #	SERVIC E	PRINT CHECK	CLERK
ERROR CORR	VALID	CLEAR	#/NS	X/TIME	5	10	15	EAT IN	ADD CHECK
VOID	TAX	7	8	9	4	9	14	TAKE OUT	CHARG E2
CANCEL	RETURN	4	5	6	3	8	13	DRIVE THRU	CHARG E1
% 1	CONV 1	1	2	3	2	7	12	SBTL	CHECK
% 2	CONV 2	0	00	.	1	6	11	CASH	

Operating Instructions

Function Key Descriptions

Keys are listed in alphabetical order. Some of the keys described below are not included on the default keyboard. See “Function Key Assignment Programming to add or change programmable keys.

Keyboard Legend	Description
#/NS	Use as a non-add key to print up to a 8-digit numeric entry on the receipt and journal. This entry will not add to any sales totals. The #/NS key is also used to open the cash drawer without making a sale.
X/TIME	Use to multiply a quantity of items or calculate split pricing on PLU entries.
00, 0-9, Decimal	Use to make numeric entries in REG, X, Z, VOID, or P positions. The decimal key is used for decimal or scale multiplication, when setting or entering fractional percentage discounts, or when programming fractional tax rates. Do not use the decimal key when making amount entries into PLUs.
ADD CHECK	Use to combine individual trays (in a cafeteria situation) that will be paid together. Each tray subtotal can advance the consecutive number, depending on programming.
CANCEL	Cancels a transaction without updating PLU, or function key totals. The Cancel function may only be used prior to tendering. Once tendering begins, the Cancel function may no longer be used. The CANCEL key corrects the appropriate totals and counters and the Financial report records total of transactions canceled.
CASH	Calculates the sale total including tax, finalizes the sale, and opens the cash drawer. Change computation is allowed by entering an amount before pressing the CASH key. The cash drawer will open only if the amount tendered is equal to or greater than the total amount of the sale. Post tendering is also available should a second change calculation be necessary. Re-enter the tendered amount and press the CASH key to show the new change computation. Press the CASH key a second time to issue a buffered receipt (up to 200 lines) when the receipt on/off function is OFF.

CHECK	Use to finalize check sales. Calculates the sale total including tax, finalizes the sale, and opens the cash drawer. Change computation is allowed by entering an amount before pressing the CHECK key. The cash drawer will open only if the amount tendered is equal to or greater than the total amount of the sale. Change issued will be subtracted from the cash-in-drawer total.
CHECK CASHING	Use to exchange a check for cash. Cash-in-drawer and check-in-drawer totals are adjusted.
CHECK ENDORSEMENT	Use to print a check endorsement message on an optional slip pri to program an endorsement message.
CHARGE(1-8)	Use to finalize charge sales. Calculates the sale total including tax, finalizes the sale, and opens the cash drawer. Change computation is allowed by entering an amount before pressing the CHARGE key. The cash drawer will open only if the amount tendered is equal to or greater than the total amount of the sale. Change issued will be subtracted from the cash-in-drawer total.
CHECK #	The CHECK # key is used to begin a new, or access an existing balance (hard check) or itemized bill (soft check.) Check track numbers that are entered manually may be set at a fixed length of one to nine digits. Check track numbers assigned automatically will begin with #1. Existing checks are accessed by entering the check track number and pressing the CHECK # key.
CLEAR	Use to clear entries made into the 10 key numeric pad or X/TIME key before they are printed. Also used to clear error conditions.
CLERK	The register will not operate in register mode unless a clerk has been signed on. Clerk sign-on is accomplished by direct or secret code sign on. All entries made on the register will report to one of the 15 clerk totals. When a clerk is signed on, all entries following will add to that clerk's total until another clerk is signed on. However, a clerk cannot be changed in the middle of a transaction. To sign a clerk off, thereby displaying the "CLOSEd" message on the display, enter 0 (zero), then press the CLERK key. This disables the register until another clerk is signed on. The current clerk must first be signed off before another clerk may be signed on.
CONV (1 & 4)	The currency conversion function, allowed after subtotal, converts and displays the new subtotal at a preprogrammed exchange rate. Tendering is allowed after using the currency conversion function. Change is calculated and issued in home currency. The amount of foreign currency tendered is stored in a separate total on the Financial report, but not added to the drawer total.
DETAIL FEED	Advances the detail paper one line, or continuously until the key is released.
EAT-IN TAKE OUT DRIVE THRU	Eat-In, Take Out and Drive Thru are subtotal functions. In areas that have different tax rules for eat-in and take out sales, the EAT-IN , TAKE OUT and DRIVE THRU keys can be programmed to automatically charge or exempt taxes. Sales may not be split between Eat-In, Take Out and Drive Thru. The EAT-IN , TAKE OUT and DRIVE THRU keys maintain separate

	totals on the Financial report.
ERROR CORR	Use to correct the last entry. The ERROR CORR key corrects the appropriate totals and counters.
F/S SHIFT	When pressed before a PLU entry, the F/S SHIFT key reverses the preprogrammed food stamp status of the PLU. For example, an item not food stamp eligible can be made food stamp eligible.
F/S SUB	Displays the amount of the sale that is food stamp eligible.
F/S TEND	Use to tender food stamps for eligible sales.
GUEST #	Use to enter the count of guests served as part of a guest check.
MACRO (1-10)	Macro keys may be programmed to record, then later perform, up to 50 keystrokes. For example, a macro key could be set to tender (preset tender) a common currency, such as €5 into the cash key.
RETURN	Used to return or refund merchandise. Returning an item will also return any tax which may have been applied.
MODIFIER 1-5	The Modifier key alters the next PLU registered, either by changing the Code number of the PLU so that a different item is registered, or by adding the modifier descriptor .
P/BAL	Use to enter the amount of an outstanding balance.
PAID OUT	Use to record money taken from the register to pay invoices, etc. The paid out amount subtracts from the cash-in-drawer total. Paid outs are allowed outside of a sale only.
% Keys 1- 5	Up to five % keys may be placed on the keyboard. Each % key is set with a specific function, such as item discount or surcharge, or sale discount or surcharge. The percent rate may be entered or preprogrammed, or the percent keys can be programmed with a negative open or preset price, thus acting as coupon keys. A percentage key may also be set up to accept charge tip entries.
PLU	The PLU key is used to register price look ups by number entry. PLUs can be programmed open or preset, and positive or negative.
PAYMENT	Use to Charge Posting Feature.
PRINT CHECK	Use to print a guest check. The check can be printed on an optional (RS-232C) printer, or can be printed on the receipt printer. The PRINT CHECK key can be set to automatically service the check.
PROMO	The PROMO key allows you to account for promotional items, as in "buy two, get one free". Pressing this key will remove an item's cost from the sale, but will include the sale of the item in the item's sales counter.
RCPT FEED	Advances the receipt paper one line, or continuously until the key is released.
RECEIPT ON/OFF	When 'OFF' no receipt will print during a sale. (If the receipt is off, a buffered receipt is available by pressing the CASH key a second time.)
RECD ACCT	The RECD ACCT (received on account) key is used to record media loaned to the cash drawer, or payments received outside of a sale. The cash drawer will open. The amount received adds to the cash-in-drawer total.

SCALE	Use to make weight entries. When a scale is attached, press the scale key to show the weight in the display, then press (or enter) a PLU to multiple the weight times the price. When a scale is not attached, you can enter the weight (using the decimal key for fractions). PLUs may be programmed to require an entry through the scale key.
SERVICE	Use to temporarily finalize Previous Balance or Table tracking transactions.
SBTL	Displays subtotal of sale including tax. Must be pressed prior to a sale discount or sale surcharge.
TABLE #	Tracks the current balance for a guest check or table.
TARE	Tares are container weights. If you are using the scale function, you can preset up to 5 different tare weights. The tare can be subtracted automatically when a specific PLU is registered, or the tare can be subtracted by manually inputting the tare number and pressing the TARE key. Tare #5 can be programmed for entering tare weights manually.
TAX EXEMPT	Press the TAX EXEMPT key to exempt tax 1, tax 2, tax 3, and/or tax 4 from the entire sale.
TAX (1-4)	When pressed before a PLU entry, the tax keys reverse the tax status of the PLU, i.e., a PLU with non-tax status would become taxable or a PLU with tax status would become non-taxable.
TIP	The TIP key allows a gratuity to be added to a guest check before payment. The tip amount is deducted from the Cash-in-Drawer amount for the Clerk/Cashier closing the guest check. The TIP key may be programmed as either a percentage or amount. If programmed as a percentage, tax programming defines whether the percentage is calculated on the net amount, or the amount after taxes.
VOID	Use to correct an item entered earlier within a sale. The VOID key corrects the appropriate totals and counters. To correct the last item, use the ERROR CORR key. For void operations outside of a sale (Transaction Void), use the VOID position on the control lock. The Financial report records totals for each type of void separately.
VALID	Press the VALID key to print a one line validation on a separate form or piece of paper. Any item registration, discount or payment may be validated. If validation is required after a particular function, the message " SP " will appear on the front display.
WASTE	The WASTE key allows control of inventory by accounting for items which must be removed from stock due to spoilage, breakage or mistakes. Press the WASTE key before entering wasted items, then press the WASTE key again to finalize. The WASTE key may be under manager control, requiring the control lock to be in the X position. The WASTE key is not allowed within a sale.

Clerk Sign-On/Sign-Off

See "System Option Programming" to review your clerk options:

- System option #2 allows you to select direct or code entry sign on and/or stay-down or pop-up operation.

Depending on how your machine has been programmed, sign-on will take place only at the beginning of a shift (stay-down), or may have to be repeated for each transaction (pop-up). If your machine has been programmed for stay-down clerks, the clerk currently signed on must be signed off before another clerk may be signed on.

Check with your store manager to see which options have been selected for your register.

Before any transaction may take place, a clerk must be signed on. Clerk sign-on is accomplished in one of two ways:

Direct Sign-On

To sign on a clerk, enter the clerk number and press the clerk key.

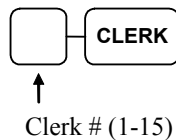

To sign the clerk off, enter 0 (Zero) and press the clerk key.

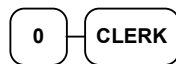

Coded Sign-On

To sign on a clerk, press the clerk key, enter the clerk code, then press the clerk key again.

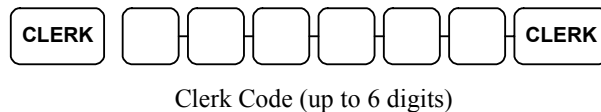

To sign the clerk off, enter 0 (Zero) and press the clerk key.

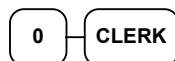

Receipt On and Off

The **RECEIPT ON/OFF** function key may or may not be located on your keyboard.

If the **RECEIPT ON/OFF** Key is Located On The Keyboard

1. Press the **RECEIPT ON/OFF** key once to turn the receipt *off*.
2. Press the **RECEIPT ON/OFF** key again to turn the receipt *on*.

If The **RECEIPT ON/OFF** Key Is Not Located On The Keyboard

1. Turn the control lock to the **X** position.
2. To turn the receipt *off*, enter **9 9**, press the **SBTL** key. Enter **1**, press **CASH**.



3. To turn the receipt *on*, enter **9 9**, press the **SBTL** key. Enter **0**, press **CASH**.



Item Registrations

All registrations on *ER-5200/40/15* are made into open or preset PLUs.

- In place of traditional PLU keys, some PLUs are located directly on the keyboard.
- When more items or categories are needed than the number of PLUs available on the keyboard, registrations can be into PLUs by entering the PLU code number and pressing the **PLU** key on the keyboard.

This system simplifies reporting by listing all items (regardless of how they are entered) on the PLU report, while reporting for groups of items or categories is available from the Group report

Open Keyboard PLU Entry

1. Enter an amount on the ten key pad. *Do not use the decimal key.* For example, for €2.99, enter:

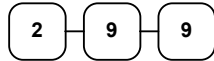

2. Press a PLU key. For example, press PLU 1:



```
THANK-YOU  
CALL AGAIN  
  
DATE 01/15/2003 WED    TIME  
08:33  
  
PLU1 T1  
€2.99  
TAX1  
€0.18  
TOTAL  
€3.17  
CASH  
€3.17  
CLERK 1                No.000011  
00001
```

Preset Price Keyboard PLU

A preset PLU registers the price that was previously programmed for the PLU. See "PLU Programming" in the "Program Mode Programming" chapter to program preset prices.

1. Press a preset PLU key. For example, press PLU 5:



```
THANK-YOU  
CALL AGAIN  
  
DATE 01/15/2003 WED    TIME  
08:33  
  
PLU5  
€1.29  
TOTAL  
€1.29  
CASH  
€1.29  
CLERK 1                No.000011  
00001
```

Keyboard PLU Repeat Entry

Open or preset price PLUs can be repeated as many times as necessary by pressing the same PLU again. The number of times the item is repeated is shown on the display.

1. Enter an amount on the ten key pad. Do not use the decimal key. For example, for €2.99, enter:



2. Press a PLU key. For example, press PLU 1:



3. To register a second item exactly as the first, press the PLU key a second time. For example, press PLU 1:

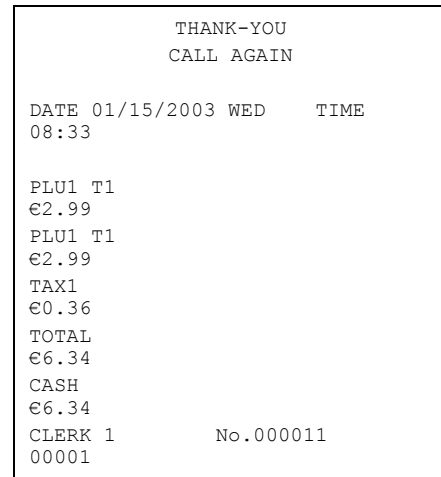
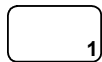

Keyboard PLU Multiplication

When several of the same items are to be entered into the same PLU, you can use multiplication. You can enter a quantity (1 to 999.999) using the **X/TIME** key. You can multiply open or preset PLUs.

1. Enter the quantity of items being purchased, press the **X/TIME** key. For example, enter **4** on the numeric key pad and press the **X/TIME** key:



2. Enter an amount on the ten key pad. Do not use the decimal key. For example, for €1.99, enter:

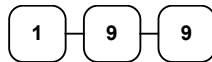

3. Press a PLU key. For example, press **PLU 1**:



```
THANK-YOU
CALL AGAIN

DATE 01/15/2003 WED    TIME
08:33

4                @€1.99
PLU1 T1
€7.96
TAX1
€0.48
TOTAL
€8.44
CASH
€8.44
CLERK 1        No.000011
00001
```

Keyboard PLU Multiplication with Decimal Point

If you are selling items by weight, or if you are selling yard goods, you can multiply a fraction of a unit.

1. Enter the amount with the decimal point, press the **X/TIME** key. For example, for 3.75 pounds of produce, enter:

3 . 7 5 X/TIME

2. Enter an amount on the ten key pad. *Do not use the decimal key.* For example, if the price is €0.99 per pound, enter:

9 9

3. Press a PLU key. For example, press **PLU 1**:

1

```
THANK-YOU
CALL AGAIN

DATE 01/15/2003 WED   TIME 08:33

3.75           @€0.99
PLU1 T1
€3.71
TAX1
€0.22
TOTAL
€3.93
CASH
€3.93
CLERK 1       No.000011
00001
```

Split Pricing (Keyboard PLU)

When items are priced in groups, i.e. 3 for €1.00, you can enter the quantity purchased and let the register calculate the correct price.

1. Enter the quantity purchased, press the **X/TIME** key. For example, enter:



2. Enter the quantity of the group price, press the **X/TIME** key. For example, if the items are priced 3 for €1.00, enter:



3. Enter an amount on the ten key pad. For example, if the items are priced 3 for €1.00, enter:

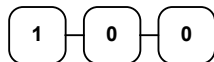

4. Press a PLU key. For example, press PLU 1:



```
THANK-YOU
CALL AGAIN

DATE 01/15/2003 WED   TIME 08:33

2@3FOR           @€1.00
PLU1 T1
€0.67
TAX1
€0.04
TOTAL
€0.71
CASH
€0.71
CLERK 1           No.000011
00001
```

Single Item Keyboard PLU

Single item PLUs automatically total as a cash sale immediately after registration. Use single item PLUs for speedy one item sales. For example if you are selling admission tickets, and all ticket sales are one item sales, you can use an open or preset PLU. After each registration, the drawer will immediately open, and a separate transaction receipt is printed. See "PLU Programming" in the "Program Mode Programming" chapter to program a single item PLU.

1. Press a single item preset PLU key. (or enter a price and press a single item open PLU key.) For example, press PLU 6:



```
THANK-YOU  
CALL AGAIN  
  
DATE 01/15/2003 WED    TIME 08:33  
  
PLU6  
€1.29  
TOTAL  
€1.29  
CASH  
€1.29  
CLERK 1                No.000011  
00001
```

Open Code Entry PLU

If the PRESET status of a PLU is set to N (no), the PLU will operate as an open PLU. See "PLU Programming" in the "Program Mode Programming" chapter to program PLU descriptors and options.

1. Enter the PLU number; press the PLU key. For example, enter:



2. The display will prompt "ENTER PRICE". Enter an amount on the ten key pad. *Do not use the decimal key.* For example, for €2.99, enter:



3. Press the PLU key again.



```
THANK-YOU
CALL AGAIN

DATE 01/15/2003 WED   TIME 08:33

PLU2 T1
€2.99
TAX1
€0.18
TOTAL
€3.17
CASH
€3.17
CLERK 1           No.000011
00001
```

Preset Price Code Entry PLU

1. Enter the PLU number; press the PLU key. For example, enter:



```
THANK-YOU
CALL AGAIN

DATE 01/15/2003 WED   TIME 08:33

PLU1
€1.29
TOTAL
€1.29
CASH
€1.29
CLERK 1           No.000011
00001
```

Code Entry PLU Multiplication

When several of the same items are to be entered into the same PLU, you can use multiplication. You can enter a quantity (1 to 999.999) using the **X/TIME** key. You can multiply open or preset PLUs.

1. Enter the quantity of items being purchased, press the **X/TIME** key. For example, enter **4** on the numeric key pad and press the **X/TIME** key:



2. Enter the PLU number; press the **PLU** key. For example, enter:



```
THANK-YOU
CALL AGAIN

DATE 01/15/2003 WED   TIME 08:33

4                @€1.99
PLU1 T1
€7.96
TAX1
€0.48
TOTAL
€8.44
CASH
€8.44
CLERK 1         No.000011
00001
```

Code Entry PLU Multiplication with Decimal Point

If you are selling items by weight, or if you are selling yard goods, you can multiply a fraction of a unit.

1. Enter the quantity with the decimal point, press the **X/TIME** key. For example, for 3.75 pounds of produce, enter:

3 . 7 5 X/TIME

2. Enter the PLU number; press the **PLU** key. For example, enter:

3 PLU

```
THANK-YOU
CALL AGAIN

DATE 01/15/2003 WED    TIME 08:33

3.75           @€2.99
PLU3 T1
€11.21
TAX1
€0.67
TOTAL
€11.88
CASH
€11.88
CLERK 1       No.000011
00001
```

Split Pricing Code Entry PLU

When items are priced in groups, i.e. 3 for €1.00, you can enter the quantity purchased and let the register calculate the correct price.

1. Enter the quantity purchased, press the **X/TIME** key. For example, enter:

2 X/TIME

2. Enter the quantity of the group price, press the **X/TIME** key. For example, if the items are priced 3 for €1.00, enter:

3 X/TIME

3. Enter the PLU number; press the **PLU** key. For example, enter:

3 PLU

```
THANK-YOU
CALL AGAIN

DATE 01/15/2003 WED    TIME 08:33

2@3FOR        @€2.99
PLU3 T1
€1.99
TAX1
€0.12
TOTAL
€2.11
CASH
€2.11
CLERK 1       No.000011
00001
```

Modifier Key

Pressing a modifier key alters the next PLU registered, either by changing the code number of the PLU so that a different item is registered, or by just adding the modifier descriptor and registering the same PLU. See "Modifier 1-5" in the "Program Mode Programming" chapter in order to determine how the modifier key will affect the PLU entry.

Modifiers can be:

- *stay down* so that registrations will be modified by the same modifier until another modifier is selected,
- *pop-up after each item* to register, for example large, medium or small soft drink,
- *pop-up after each transaction* to register, for example, toppings of various pizza sizes.

See "System Options" in the "Program Mode Programming" chapter to select stay down/pop-up status.

Pop-Up Modifier Key Affecting PLU Code

1. Press a preset PLU key. For example, press PLU **1** with a price of €1.00.



2. Press the **MOD 1** key. The message "MOD1" displays.

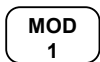

3. Press the same PLU key. In this example the modifier 1 will add the digit 1 to the fourth PLU # position, resulting in the registration of PLU #1001.



4. Press another PLU key. In this example press PLU **2** with a price of €1.50.

```
THANK-YOU  
CALL AGAIN  
  
DATE 01/15/2003 WED   TIME 08:33  
  
PLU1  
€1.00  
MOD1  
#1001  
€1.25  
PLU2  
€1.50  
TOTAL  
€3.75  
CASH  
€3.75  
CLERK 1           No.000011  
00001
```

Price Level Key

If you choose to use the price level feature, you must allocate memory for each level. See "Memory Allocation" in the "Service Mode Programming" chapter. Note that the default program selects one price level. You must also place price level keys on the keyboard. See "Function Key Assignment" in the "Program Mode Programming" chapter.

If you use this feature, the same PLU can be given up to 5 different preset prices. Price Level keys shift the price that is being registered. Levels can be:

- *stay down* so that registrations will stay in the selected level until another level is selected,
- *pop-up after each item* to register, for example large, medium or small soft drink,
- *pop-up after each transaction* to register, for example, toppings of various pizza sizes.

See "System Options" in the "Program Mode Programming" chapter to set how the price level keys operate.

Pop-Up Price Level Keys

1. Press a preset PLU key. For example, press PLU 1 programmed with a price of €1.00 for price level 1.

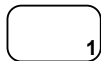

2. Press the **LEVEL 2** key. The message "LEVEL 2" displays.

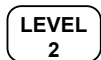

3. Press the same PLU key. In this example the PLU 1 key is programmed with a price of €2.00 for price level 2.

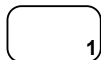

4. Press another PLU key. In this example press PLU 2 programmed to register PLU #2 with price level 1. Note that the level 1 price is registered.

```
THANK-YOU
CALL AGAIN

DATE 01/15/2003 WED   TIME 08:33

PLU1
€1.00
PLU1
€2.00
PLU2
€1.50
TOTAL
€4.50
CASH
€4.50
CLERK 1                No.000011
00001
```

Promo

The **PROMO** key allows you to account for promotional items, as in "buy two, get one free". Pressing this key will remove an item's cost from the sale, and the promo item will not be added to the PLU sales total, but it is added to the item sales counter. If stock (inventory) reporting is used, the item will be subtracted from inventory.

1. Register an item. For example, press **PLU 1** programmed with a price of €1.00 for price level 1.

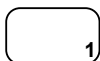

2. Press the **PROMO** key. The message "PROMO" displays.



3. Enter the item to be promo'd. You can not enter an item that has not been already registered in this transaction.

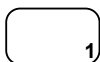

```
THANK-YOU  
CALL AGAIN  
  
DATE 01/15/2003 WED   TIME 08:33  
  
PLU1  
€1.00  
  
***PROMO***  
  
PLU1  
TOTAL  
€0.00  
CASH  
€0.00  
CLERK 1           No.000011  
00001
```

Waste

The **WASTE** key allows control of inventory by accounting for items that must be removed from stock due to spoilage, breakage or mistakes. Press the **WASTE** key before entering wasted items, and then press the **WASTE** key again to finalize. The **WASTE** key may be under manager control, requiring the control lock to be in the **X** position. The **WASTE** key is not allowed within a sale.

1. Press the **WASTE** key. The message "WASTE" displays at the top of the screen.

WASTE

2. Enter the item or items that are wasted.
3. Press the **WASTE** key again to total the wasted items:

WASTE

```
THANK-YOU  
CALL AGAIN  
  
DATE 01/15/2003 WED    TIME 08:33  
  
***WASTE***  
PLU1  
€1.25  
PLU2  
€1.50  
  
***WASTE***  
  
TOTAL  
€2.75  
CLERK 1          No.000011  
00001
```

Shifting or Exempting Tax

Shifting Tax

PLUs can be programmed to automatically add the appropriate tax or taxes. Occasionally, you may need to sell a normally taxable item without tax, or a normally non-taxable item with tax. You can perform this tax shifting with one of the four tax keys.

1. Press the tax shift for the tax you wish to shift. For example, Press **TAX 1**:

TAX1

2. Enter an amount on the ten key pad. *Do not use the decimal key.* For example, for €2.99, enter:

2 9 9

3. Press a PLU key. For example, press PLU 1. If PLU 1 is normally taxable by tax 1, the registration will be non-taxable.

1

```
THANK-YOU  
CALL AGAIN  
  
DATE 01/15/2003 WED    TIME 08:33  
  
PLU1  
€2.99  
TOTAL  
€2.99  
CASH  
€2.99  
CLERK 1                No.000011  
00001
```

Exempting Tax

Occasionally, you may need to exempt tax from an entire sale. For example, you might remove all state and local taxes when you sell merchandise to a church or charitable institution.

You can exempt tax by using the tax shift keys and the **SUBTOTAL** key, or you can use the **TAX EXMT** (tax exempt) function key.

Exempting Tax with Tax Keys

1. Enter an amount on the ten key pad. Do not use the decimal key. For example, for €2.99, enter:

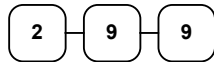

2. Press a taxable PLU key. For example, press **PLU 1**:

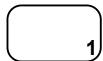

3. Press **SBTL**:

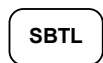

4. Press the tax key (or keys) that represents the tax you wish to shift. For example, to exempt tax 1 press **TAX 1**, then press **SBTL**:



5. The display reflects the transaction without added taxes. Total the sale with **CASH**, **CHECK**, or a **CHARGE** function. The sale will not include tax 1.

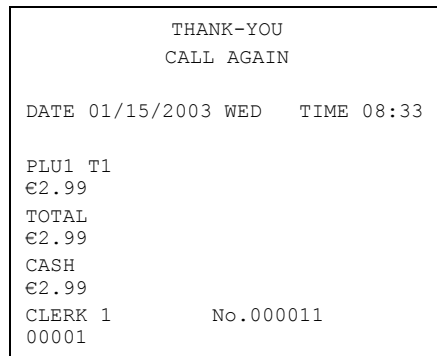

Exempting Tax with the Tax Exempt Key

You can program the **TAX EXMT** function to remove all or selected taxes.

1. Enter an amount on the ten key pad. Do not use the decimal key. For example, for €2.99, enter:

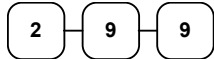

2. Press a taxable PLU key. For example, press **PLU 1**:

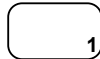

3. Press **SBTL**:



4. Press the **TAX EXMT** key:



5. The display reflects the transaction without added taxes. Total the sale with **CASH**, **CHECK**, or a **CHARGE** function. The sale will not include tax 1.

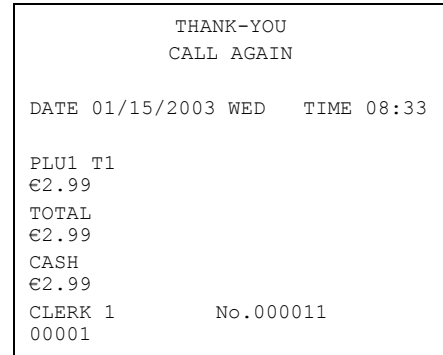

Percent Key Operations

A total of five % functions are available. %1 and %2 are located on the default keyboard. Your keyboard may be different. More or less % keys may be located on the keyboard, or they may be located on one of the function look up menu keys.

Each function is individually programmable to add or subtract, from an individual item or from a sale total, amounts (coupons) or percentages. You can also program the percentage key taxable or non-taxable, so that sales taxes are calculated on the net, or the gross amount of the item or sale. You can also program preset prices or percentages.

The operation examples in this section show the percentage key in a variety of configurations. See "Function Key Programming" in the "Program Mode Programming" chapter to assign a specific function to each percentage key.

Preset Percent Discount on an Item

In this example the %1 function is preset with a rate of 10 %.

1. Register the item.
2. Press the %1 key:

% 1

3. The discount is automatically subtracted.

```
THANK-YOU
CALL AGAIN

DATE 01/15/2003 WED   TIME 08:33

PLU2
€10.00
% 1                -
10.000%
AMOUNT            -
1.00
TOTAL
€9.00
CASH
€9.00
CLERK 1          No.000011
0001
```

Enter a Percent Discount on an Item

You can also operate the percentage functions by entering the percentage of the discount or surcharge. If necessary, you can enter a fractional percentage up two 3 digits beyond the decimal (i.e. 99.999%).

1. Register the discounted item.
2. Enter the percentage. If you are entering a fraction of a percent, you must use the decimal key. For example, for one third off enter:

3 3 . 3 3 3

3. Press the %1 key:

% 1

4. The discount is automatically subtracted.

```
THANK-YOU
CALL AGAIN

DATE 01/15/2003 WED   TIME 08:33

PLU2
€10.00
% 1                -
33.333%
AMOUNT            -
3.33
TOTAL
€6.67
CASH
€6.67
CLERK 1           No.000011
00001
```

Percent on Sale Total

The percent can be an open or preset amount. In this example an open percentage surcharge of 15% is applied.

1. Register the items you wish to sell.
 2. Press the SBTL key:
- SBTL
3. Enter the percentage, press the appropriate discount key. For example, for 15% enter:

1 5 %1

4. The surcharge is automatically added.

```
THANK-YOU
CALL AGAIN

DATE 01/15/2003 WED   TIME 08:33

PLU2
€10.00
% 1                -
15.000%
AMOUNT            -
€1.50
TOTAL
€11.50
CASH
€11.50
CLERK 1           No.000011
00001
```

Coupon on Sale (Vendor Coupon)

When programmed as "amount", "sale", "open" and "negative", a % key will perform a coupon against a sale (or vendor coupon.) Also, depending upon programming:

- You may be allowed to enter only one coupon in a sale, after the **SBTL** key is pressed,
- You may be allowed to enter multiple coupons, but you must press the **SBTL** key before each coupon entry, or
- You may be allowed to enter multiple coupons, without first pressing **SBTL**.

In this example, a coupon may be entered only once, and you must first press **SBTL**.

1. Register the items you wish to sell.

2. Press the **SBTL** key:

SBTL

3. Enter the amount of the coupon, press the appropriate % key. For example:

2 0 0 % 1

4. The coupon is subtracted.

```
THANK-YOU  
CALL AGAIN  
  
DATE 01/15/2003 WED    TIME 08:33  
  
PLU2  
€10.00  
%1  
2.00  
TOTAL  
€8.00  
CASH  
€8.00  
CLERK 1                No.000011  
00001
```

Coupon on Item (Store Coupon)

When programmed as "amount", "item", "open" and "negative", a % key will perform a coupon against an item (or store coupon.) In this case, you must press the PLU (or enter the PLU number) of the PLU you wish the coupon to be subtracted from.

1. Register the items you wish to sell.
2. Enter the amount of the coupon, press the appropriate % key. For example:

2 0 0 % 1

3. Press the PLU key you wish to subtract the coupon from (or enter the PLU number of the PLU you wish to subtract the coupon from and press **PLU**.)

1

4. The coupon is automatically subtracted.

```
THANK-YOU
CALL AGAIN

DATE 01/15/2003 WED   TIME 08:33

PLU1
€10.00
PLU1 C                -
2.00
TOTAL
€8.00
CASH
€8.00
CLERK 1                No.000011
00001
```

Return Merchandise Registrations

If you wish to return or refund an item, press **RETURN**, then re-enter any item. You can return merchandise as part of a sale, or you can return merchandise as a separate transaction and return cash to the customer.

1. Press **RETURN**:

RETURN

2. Enter the price of the item you wish to return, then press the PLU key where it was registered originally.

2 9 9 2

3. Total the sale with **CASH**, **CHECK**, or a **CHARGE** function.

```
THANK-YOU
CALL AGAIN

DATE 01/15/2003 WED    TIME 08:33

RETURN *****
PLU2 T1                -
2.99                   -
TAX1 AMT                -
0.18                   -
TOTAL                  -
3.17                   -
CASH                   -
3.17
CLERK 1                No.000011
00001
```

Voids and Corrections

Error Correction (Void Last Item)

This function corrects the last item entered.

1. Register the item you wish to sell.
2. Press the **ERROR CORR** key:

**ERROR
CORR**

```
THANK-YOU  
CALL AGAIN  
  
DATE 01/15/2003 WED   TIME 08:33  
  
PLU1 T1                €2  
29  
PLU2  
€1.29  
ERR CORR -----  
PLU2                    -  
1.29  
TAX1 AMT  
€0.14  
TOTAL  
€2.43  
CASH  
€2.43  
CLERK 1                No.000011  
00001
```

Void Previous Item

This function allows you to correct an item registered previously in a transaction.

1. Register an item. Then register a second item.
2. To correct the first item, press **VOID:**

VOID

3. Enter the price of the first item, then press the PLU key where it was registered originally.

1 2 9 2

```
THANK-YOU  
CALL AGAIN  
  
DATE 01/15/2003 WED   TIME 08:33  
  
PLU2  
€1.29  
PLU1 T1                €2.29  
€2.29  
VOID -----  
PLU2                    -  
1.29  
TAX1 AMT  
€0.14  
TOTAL  
€2.43  
CASH  
€2.43  
CLERK 1                No.000011  
00001
```

Cancel

The **CANCEL** key allows you to stop any transaction. Anything registered within the transaction before the **CANCEL** key is pressed is automatically corrected. The **CANCEL** key can be inactivated through programming, see "Function Key Programming" in the "Program Mode Programming" chapter, or the key can be programmed to require manager control.

1. Register the items you wish to sell.
2. Press the **CANCEL** key

CANCEL

```
THANK-YOU
CALL AGAIN

DATE 01/15/2003 WED   TIME 08:33

PLU1 T1
€2.29
PLU2                    -
0.50
CANCEL *****
CLERK 1                No.000011
00001
```

Void Position Operations

You can use the **VOID** control lock position to correct any complete transaction. To correct any transaction:

1. Turn the control lock to the **VOID** position.
2. Enter the transaction you wish to correct exactly as it was entered originally in the **REG** control lock position. You can enter discounts, voids, returns, tax exemptions or any other function.
3. All totals and counters are corrected as if the original transaction did not take place.

```
THANK-YOU
CALL AGAIN

DATE 01/15/2003 WED   TIME 08:33

VOID MODE *****
PLU1 T1                    -
2.29
PLU2                    -
1.00
TAX1 AMT                  -
0.14
TOTAL                    -
3.43
CASH                    -
3.43
CLERK 1                No.000011
00001
```

No Sale Operations

Open Drawer

The **#/NO SALE** key will open the cash drawer when you have not already started a transaction. The no sale function can be disabled or placed under manager control through programming, see "Function Key Programming" in the "Program Mode Programming" chapter.

1. Press **#/NS**:



2. The drawer will open and the receipt will print as in the example on the right.

```
THANK-YOU
CALL AGAIN

DATE 01/15/2003 WED   TIME 08:33

NO SALE -----
CLERK 1                No.000011
00001
```

Non Add Number

You can also use the **#/NO SALE** key to print any number (up to 9 digits) on the printer paper. You can enter the number any time during a transaction. For example, if you wish to record a checking account number, enter the number and press the **#/NO SALE** key before totaling the sale with the **CHECK** key.

1. Register the items you wish to sell.
2. Enter the number you wish to record, for example enter:



3. Press **#/NS**:



4. Press **CHECK**:



```
THANK-YOU
CALL AGAIN

DATE 01/15/2003 WED   TIME 08:33

PLU1 T1
€2.99
NON-ADD#
1234
TAX1 AMT
€0.18
TOTAL
€3.17
CHECK
€3.17
CLERK 1                No.000011
00001
```

Received On Account Operations

You can use one of the received on account functions (**RA1-RA3**) to accept cash or checks into the cash drawer when you are not actually selling merchandise. For example, use received on account to accept payments for previously sold merchandise, or record loans to the cash drawer.

1. Press one of the received on account keys (**RA1-RA3**)

RA1

2. Enter the amount of cash received, press **CASH**.

1 0 0 0 CASH

3. Enter the check amount received, press **CHECK**.

1 0 0 0 CHECK

4. Enter the charge amount received, press **CHARGE1**

1 0 0 0 CHARGE 1

5. You can continue to itemize receipts, or you can finalize by pressing or selecting the same received on account key.

RA1

```
THANK-YOU
CALL AGAIN

DATE 01/15/2003 WED   TIME 08:33

RA1
CASH
€10.00
CHECK
€10.00
CHARGE1
€10.00
RA1
€30.00
CLERK 1                No.000011
00001
```

Paid Out Operations

You can use the paid out function(**PO1-PO3**) to track cash or checks paid out or to record loans from the cash drawer.

1. Press one of the paid out keys (**PO1-PO3**)

PO1

2. Enter the amount of cash paid out, press **CASH**.

1 **0** **0** **0** **CASH**

3. Enter the check amount paid out, press **CHECK**.

1 **0** **0** **0** **CHECK**

4. Enter the charge amount received, press **CHARGE1**

1 **0** **0** **0** **CHARGE**
1

5. You can continue to itemize paid outs, or you can finalize by pressing or selecting the same paid out key.

PO1

```
THANK-YOU
CALL AGAIN

DATE 01/15/2003 WED   TIME 08:33

PO1
CASH                    -
10.00
CHECK                   -
10.00
CHARGE1                 -
10.00
PO1                      -
30.00
CLERK 1                 No.000011
00001
```

Subtotaling a Sale

1. Register the items you wish to sell.
2. Press **SBTL**. The subtotal will display with the message "Sub" indicated on the rear display.

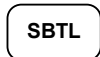

The subtotal can be printed if the system option is set. See "Print Option Programming" in the "Program Mode Programming" chapter.

Eat In/Take Out/Drive Thru Sales

Different types of sales, such as "Eat In", "Take Out" and "Drive Thru" can be categorized by placing separate keys on the keyboard. **EAT IN**, **TAKE OUT**, and **DRIVE THRU** keys function as subtotal keys. You can force the operator to press one of the keys before tendering. See "System Option Programming" in the "Program Mode Programming" chapter. Separate totals will be maintained on the financial report to detail sales counts and amounts for each key.

Totaling and Tendering

There are ten tender functions available to categorize sales. **CASH** and **CHECK** are individual keys on the keyboard

Totaling a Cash Sale

1. Register the items you wish to sell.
2. To total a cash sale, press **CASH**:

CASH

3. The display will indicate the total amount of the cash sale.

```
THANK-YOU  
CALL AGAIN  
  
DATE 01/15/2003 WED    TIME 08:33  
  
PLU2  
€7.96  
TOTAL  
€7.96  
CASH  
€7.96  
CLERK 1                No.000011  
00001
```

Totaling a Check Sale

1. Register the items you wish to sell.
2. To total a cash sale, press **CHECK**:

CHECK

3. The display will indicate the total amount of the cash sale.

```
THANK-YOU  
CALL AGAIN  
  
DATE 01/15/2003 WED    TIME 08:33  
  
PLU2  
€7.96  
TOTAL  
€7.96  
CHECK  
€7.96  
CLERK 1                No.000011  
00001
```

Tendering a Cash Sale

1. Register the items you wish to sell.
2. Enter the amount tendered by the customer. For example, for €20.00 enter:

2 0 0 0

3. Press **CASH**:

CASH

4. The display will indicate the total amount of the cash tendered and the change due, if any.

```
THANK-YOU
CALL AGAIN

DATE 01/15/2003 WED   TIME 08:33

PLU1 T1
€2.99
PLU1 T1
€2.99
4                               @€1.99
PLU2
€7.96
TAX1
€0.36
TOTAL
€14.30
CASH
€20.00
CHANGE
€5.70
CLERK 1                          No.000011
00001
```

Tendering a Check Sale

1. Register the items you wish to sell.
2. Enter the amount tendered by the customer. For example, for €20.00 enter:

2 0 0 0

3. Press **CHECK**:

CHECK

4. The display will indicate the total amount of the check tendered and the change due, if any.

```
THANK-YOU
CALL AGAIN

DATE 01/15/2003 WED   TIME 08:33

PLU1 T1
€2.99
PLU1 T1
€2.99
4                               @€1.99
PLU2
€7.96
TAX1
€0.36
TOTAL
€14.30
CHECK
€20.00
CHANGE
€5.70
CLERK 1                          No.000011
00001
```

Totaling a Charge Sale

Use the charge keys to track charge or credit card sales. See "Function Key Programming" in the "Program Mode Programming" chapter to change the descriptors for the charge tender functions. For example, you can use CHARGE 1 to track Visa card sales. The descriptor "VISA" will display on the function look up menu and print on the printer. You can also set tendering options for the charge keys, i.e. whether to allow over tendering or to enforce tendering.

1. Register the items you wish to sell.
2. Press one of the charge key if it is located on the keyboard:



```
THANK-YOU  
CALL AGAIN  
  
DATE 01/15/2003 WED    TIME 08:33  
  
PLU1 T1  
€2.99  
PLU1 T1  
€2.99  
4                @€1.99  
PLU2  
€7.96  
TAX1  
€0.36  
TOTAL  
€14.30  
CHARGE1  
€14.30  
CLERK 1          No.000011  
00001
```

Tendering a Charge Sale

Tendering a charge sale may or may not be allowed. See "Function Key Programming" in the "Program Mode Programming" chapter to set tendering options for the charge keys, i.e. whether to allow over tendering or to enforce tendering.

1. Register the items you wish to sell.
2. Enter the amount of the charge and press one of the charge keys if it is located on the keyboard:

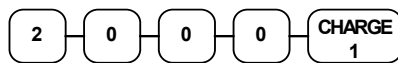

```
THANK-YOU
CALL AGAIN

DATE 01/15/2003 WED   TIME 08:33

PLU1 T1
€2.99
PLU1 T1
€2.99
4                               @€1.99
PLU2
€7.96
TAX1
€0.36
TOTAL
€14.30
CHARGE1
€20.00
CHANGE
€5.70
CLERK 1                       No.000011
00001
```

Check Cashing

Check cashing means exchanging cash for a check. If you wish to cash checks, you must place a **CHKCASH** key on the keyboard. See "Function Key Assignment" in the "Program Mode Programming" chapter.

1. Enter the amount of the check tendered by the customer. For example, for €20.00 enter:



2. Press **CHKCASH**:



3. The display will indicate the amount of the check and the cash change.

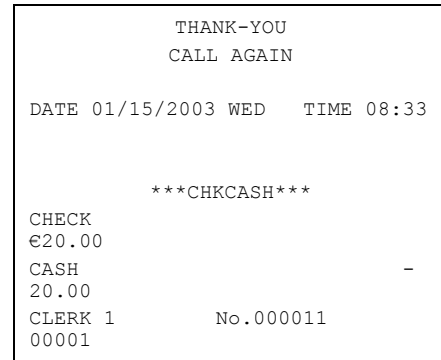

Split Tender

Split tendering is paying for one transaction by more than one payment method. For example, a €20.00 sale could be split so €10.00 is paid in cash, and the remaining €10.00 is paid by a check. If necessary, you can make several different payments.

1. Register the items you wish to sell.
2. Enter the amount of cash tendered by the customer. For example, enter €10.00 and press **CASH**:

1 0 0 0 CASH

3. The display will indicate the €10.00 cash tender and the €10.00 total still due.
4. Enter the amount of check tendered by the customer. For example, enter €10.00 and press **CHECK**:

1 0 0 0 CHECK

5. When the total tendered equals or exceeds the total due, the receipt will print and the transaction is complete.

```
THANK-YOU  
CALL AGAIN  
  
DATE 01/15/2003 WED   TIME 08:33  
  
PLU2  
€20 00  
TOTAL  
€20.00  
CASH  
€10.00  
TOTAL  
€10.00  
CHECK  
€10.00  
CLERK 1           No.000011  
00001
```

Post Tender

Post tendering means computing change after the sale has been totaled and the drawer is open. This feature is useful when a customer changes the amount of the tender or when a "quick change artist" confuses a clerk. Normally, this function is not allowed. If you wish to allow post tendering, you must set the appropriate system option.

1. Register the items you wish to sell.
2. Press **CASH**:

CASH

3. The display will indicate the total of the cash sale.
4. Enter the amount of the new tender,
Press **CASH**:

2 **0** **0** **0** **CASH**

5. The display will indicate the change due.

```
THANK-YOU  
CALL AGAIN  
  
DATE 01/15/2003 WED    TIME 08:33  
  
PLU1 T1  
€2.00  
TAX1  
€0.12  
CASH  
€2.12  
CLERK 1                No.000011  
00001
```

Food Stamp Sales

The *ER-5200 series* is capable of sorting food stamp and non-food stamp eligible items. Then if a customer chooses to pay by food stamps, the eligible total can be recalled and food stamp payments accepted.

If you choose to use this feature, you must:

- Locate the appropriate function keys on the keyboard, **F/S SHIFT**, **F/S SUB**, and **F/S TEND**, and then set the appropriate options for the **F/S TEND** key.
- Determine and set the food stamp status for each PLU item or category.

1. Register the items you wish to sell. You do not need to sort food stamp eligible or non-eligible items. The *ER-5200 series* will maintain a subtotal of eligible items based upon the pre-programmed status for each PLU.

If you wish to register a normally food stamp eligible item into a PLU programmed as non-food stamp eligible, press the **F/S SHIFT** key before registering the item. In the same manner, you can register non-food stamp items into food stamp eligible PLUs.

2. If a customer wishes to pay with food stamps, press the **F/S SUB** key to display the food stamp eligible total:



3. Enter the amount of food stamps tendered by the customer. For example, for €20.00 enter:

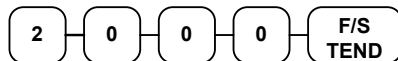

4. The remaining amount due displays. (Note, depending upon programming, change less than €1 can be applied to the balance.)
5. Total or tender the remaining balance.

```
THANK-YOU
CALL AGAIN

DATE 01/15/2003 WED   TIME 08:33

PLU1 F
€1.29
PLU2
€4.29
TOTAL
€5.58
F/S TOTAL
€1.29
F/S TEND
€20.00
F/S CRT AMT
€0.71
TOTAL
€3.58
CASH
€5.00
CHANGE
€1.42
F/S/ CHANGE
€18.00
CLERK 1           No.000011
00001
```

Currency Conversion

If you normally accept currency from neighboring nations, you can program to convert the subtotal of a sale to the equivalent cost in the foreign currency. You can set up four separate conversion functions for different foreign currencies. To do this, you need to program the conversion factor. For example, if the US dollar (home currency) is worth 1.3720 Canadian dollars (foreign currency), the conversion factor is 1.3720. See "Function Key Programming" in the "Program Mode Programming" chapter to set a conversion factor.

1. Register the items you wish to sell.
2. Press the **CONV1** key if it is located on the keyboard:



3. Enter the amount of the foreign currency tender, Press **CASH**:

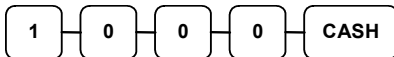

4. The display will indicate the amount of foreign currency tendered and display €5.17 change due. **The change due is computed in home currency!**

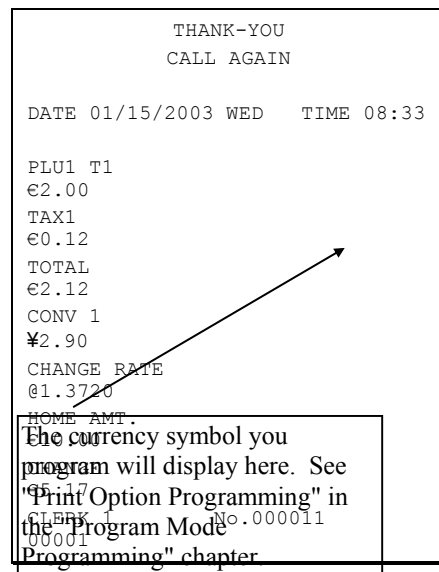

Table Management and Clerk Interrupt Operations

Overview

The *ER-5200 series* can employ a manual previous balance, hard check, or soft check system. (You must select hard or soft check posting in memory allocation programming - the default selection is soft.)

There are two methods in ER-5200 series to manage check track. One is table management system and the other is clerk interrupt system. If you want to use clerk interrupt system.

First, Program as below.

To Enter Clerk Interrupt Sytem (To Exit Table Management system)

- 1.Program Clerk Secret Code
- 2.Set system option #2 to a value of **1**. See "System Option Programming"
- 3.Set system option #26 to a value of **1**. See "System Option Programming" .

To Exit Clerk Interrupt System(To Enter Table Management system)

- ◆ Set system option #26 to a value of **0**. See "System Option Programming" .

Posting Balances Manually

Opening a Check

1. Enter the previous balance (if this is the first posting, enter **0**) press the **PBAL** key:



2. Register the items you wish to sell.
3. To total the posting, press **SERVICE**:



4. Place a slip in an optional slip printer, press the **PRINT CHECK** key.

```
THANK-YOU  
CALL AGAIN  
  
DATE 01/15/2003 WED    TIME 08:33  
  
PBAL  
€0.00  
PLU2  
€1.00  
SERVICE  
€1.00  
BFW  
€1.00  
CLERK 1                No.000011  
00001
```

Adding to a Check

1. Enter the previous balance, press the **PBAL** key:



2. Register the next items you wish to sell.
3. To total the posting, press **SERVICE**:



4. Place a slip in an optional slip printer, press the **PRINT CHECK** key.

```
THANK-YOU  
CALL AGAIN  
  
DATE 01/15/2003 WED    TIME 08:33  
  
PBAL  
€1.00  
PLU3  
€2.00  
SERVICE  
€2.00  
BFW  
€3.00  
CLERK 1                No.000012  
00001
```

Paying a Manual Balance

1. Enter the previous balance, press the **PBAL** key:

3 0 0 PBAL

2. If necessary, add additional items. If you wish to add a tip, press **SBTL**, then enter the tip amount and press the **TIP** key:

SBTL

5 0 TIP

3. Pay the balance as you would normally tender a transaction, with **CASH**, **CHECK**, or one of the **CHARGE** functions. If the tender is greater than the balance due, change is displayed:

1 0 0 0 CASH

4. Place a slip in an optional slip printer, press the **PRINT CHECK** key.

```
THANK-YOU
CALL AGAIN

DATE 01/15/2003 WED   TIME 08:33

PBAL
€3.00
TIP
€0.50
CHECKS PAID
€3.50
CASH
€10.00
CHANGE
€6.50
CLERK 1                No.000013
00001
```

Soft Check

Opening a Soft Check

1. Enter the number of the guest check, press the **CHECK #** key:



or, press the **CHECK #** key to automatically assign a check:

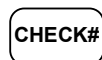

2. If required, enter the table number and press the **TABLE** key:



3. If required, enter the number of guests and press the **GUEST** key:



4. Register the items you wish to sell.
5. To total the posting, press **SERVICE**:



Receipt Example:

THANK-YOU CALL AGAIN	
DATE 01/15/2003 WED	TIME 08:33
CHECK #	
#123	
PBAL	
€0.00	
TABLE	
#3	
GUEST	
#2	
CHICKEN	
€7.00	
STEAK	
€10.00	
SERVICE	
€17.00	
BFWD	
€17.00	
CLERK 1	No.000011
00001	

Note: If a table number entry is required for all guest checks, and checks are assigned by register, the check will be assigned by the register when the table # is entered.

Adding to a Soft Check

1. Enter the number of the guest check, press the **CHECK #** key:

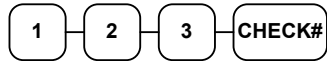

or, if you entered a table number, enter the table number and press the **TABLE** key:



2. Register the next items you wish to sell.
3. To total the posting, press **SERVICE**:



Receipt Example:



Printing a Soft Check

1. Enter the number of the guest check, press the **CHECK #** key:

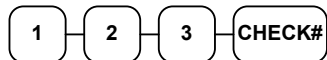

or, if you entered a table number, enter the table number and press the **TABLE** key:



2. Press **PRINT CHECK** to print the complete check. If programmed to do so, the **PRINT CHECK** key will automatically service the check:



Sample of soft check printed on the receipt:

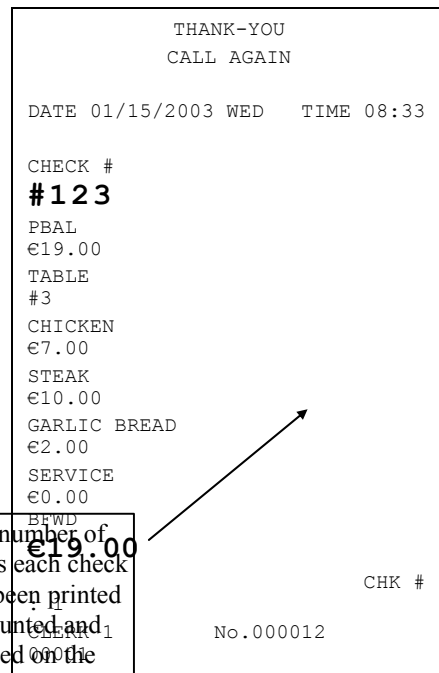

The number of times each check has been printed is counted and printed on the check

Paying a Soft Check

1. Enter the number of the guest check, press the **CHECK #** key:

1 — 2 — 3 — CHECK#

or, if you entered a table number, enter the table number and press the **TABLE** key:

3 — TABLE

2. If necessary, add additional items. If you wish to add a tip, press **SBTL**, then enter the tip amount and press the **TIP** key:

SBTL

3 — 0 — 0 — TIP

3. Pay the balance as you would normally tender a transaction, with **CASH**, **CHECK**, or one of the **CHARGE** functions. If the tender is greater than the balance due, change is displayed.

2 — 5 — 0 — 0 — CASH

Sample of soft check printed on the receipt:

```
THANK-YOU  
CALL AGAIN  
  
DATE 01/15/2003 WED   TIME 08:33  
  
CHECK #  
# 1 2 3  
PBAL  
€19.00  
TABLE  
#3  
TIP  
€3.00  
CHECKS PAID  
€22.00  
CASH  
€25.00  
CHANGE  
€3.00  
  
: 2  
CLERK 1           No.000013  
00001
```

Hard Check

Opening a Hard Check

1. Enter the number of the guest check, press the **CHECK #** key:



or, press the **CHECK #** key to automatically assign a check:



2. If required, enter the table number and press the **TABLE** key:



3. If required, enter the number of guests and press the **GUEST** key:

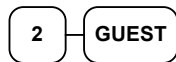

4. Register the items you wish to sell.
5. Place a slip in an optional slip printer, the check will print automatically when you press **SERVICE**:



Receipt Example:

THANK-YOU CALL AGAIN	
DATE 01/15/2003 WED	TIME 08:33
CHECK #	
#123	
PBAL	€0.00
TABLE	#3
GUEST	#2
CHICKEN	€7.00
STEAK	€10.00
SERVICE	€17.00
BFWD	€17.00
CLERK 1	No.000011
00001	

Adding to a Hard Check

1. Enter the number of the guest check, press the **CHECK #** key:

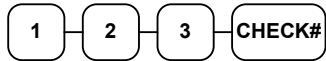

or, if you entered a table number, enter the table number and press the **TABLE** key:



2. Register the next items you wish to sell.
3. To total the posting, press **SERVICE**:



Receipt Example:

THANK-YOU CALL AGAIN	
DATE 01/15/2003 WED	TIME 08:33
CHECK #	
#123	
PBAL	
€17.00	
TABLE	
#3	
GARLIC BREAD	
€2.00	
SERVICE	
€2.00	
BFWD	
€19.00	
CLERK 1	No.000012
00001	

Paying a Hard Check

1. Enter the number of the guest check, press the **CHECK #** key:

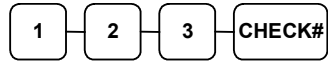

or, if you entered a table number, enter the table number and press the **TABLE** key:



2. If necessary, add additional items. If you wish to add a tip, press **SBTL**, then enter the tip amount and press the **TIP** key:



3. Pay the balance as you would normally tender a transaction, with **CASH**, **CHECK**, or one of the **CHARGE** functions. If the tender is greater than the balance due, change is displayed.

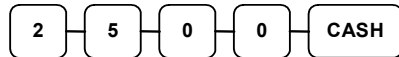

Direct Scale Entry

Place a product on the scale and access the **SCALE** function to display the weight on the cash register. Then make the appropriate entry; the PLU must have "scaleable" status.

1. Place an item on the scale.
2. Press the **SCALE** key.



3. Note that the weight is displayed on the screen. Enter the price per pound on the ten key pad. Do not use the decimal key. For example, for €3.00, enter:

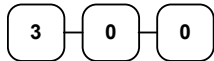

4. Press a PLU key. For example, press **PLU 1**:



```
THANK-YOU
CALL AGAIN

DATE 01/15/2003 WED   TIME 08:33

1.500 lb      @€3.00/lb
PLU1
€4.50
TAX1
€0.27
TOTAL
€4.77
CASH
€4.77
CLERK 1      No.000011
00001
```

Automatic Scale Entry

Place a product on the scale and make the appropriate PLU entry. The PLU must be set with "auto scale status".

1. Place an item on the scale.
2. Press a PLU key, if the item is a preset item, or enter the price per pound on the ten key pad. Do not use the decimal key. For example, for €3.00, enter:

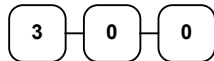

3. Press a PLU key. For example, press PLU 1:



```
THANK-YOU
CALL AGAIN

DATE 01/15/2003 WED    TIME 08:33

1.500 lb      @€3.00/lb
PLU1
€4.50
TAX1
€0.27
TOTAL
€4.77
CASH
€4.77
CLERK 1      No.000011
00001
```

Tare Weight Entry

1. Place an item on the scale.
2. Enter the preprogrammed tare number. Press the TARE key.



3. Press the SCALE key.



4. Note that the weight, less the tare weight, is displayed on the screen. Enter the price per pound on the ten key pad. Do not use the decimal key. For example, for €3.00, enter:

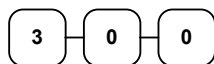

5. Press a PLU key. For example, press PLU 1:



```
THANK-YOU
CALL AGAIN

DATE 01/15/2003 WED    TIME 08:33

1.500 lb      @€3.00/lb
PLU1
€4.50
TAX1
€0.27
TOTAL
€4.77
CASH
€4.77
CLERK 1      No.000011
00001
```

Manual Tare Weight Entry

1. Place an item on the scale.
2. Enter the manual tare number, **5**. Press the **TARE** key:



3. Enter the weight of the tare, for example, enter **.01**, press the tare key:

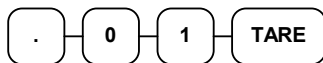

4. Press the **SCALE** key.



5. Note that the weight, less the tare weight, is displayed on the screen. Enter the price per pound on the ten key pad. Do not use the decimal key. For example, for €3.00, enter:

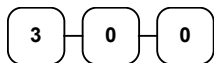

6. Press a PLU key. For example, press **PLU 1**:

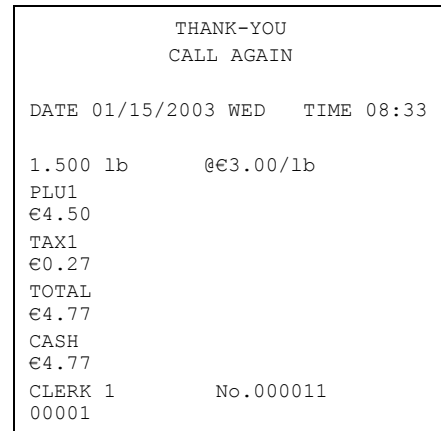

Manual Weight Entry

Operators can make manual weight entries if the item has been programmed to accept them. You must use the decimal key to enter fractional manual weights.

1. Place an item on the scale.
2. Enter the weight using the decimal key for fractional weights. Press the **SCALE** key:

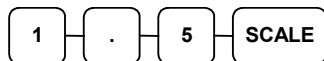

3. Enter the price per pound on the ten key pad. Do not use the decimal key. For example, for €3.00, enter:

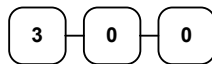

4. Press a PLU key. For example, press PLU 1:



```
THANK-YOU
CALL AGAIN

DATE 01/15/2003 WED   TIME 08:33

1.500 lb   MANUAL WT. @€3.00/lb
PLU1
€4.50
TAX1
€0.27
TOTAL
€4.77
CASH
€4.77
CLERK 1           No.000011
00001
```

X Mode

Introduction

All Management Functions take place with the control lock in the **X** position. In this way only those with the correct key will have access to these functions. Some register operations may be programmed to require the control lock in the **X** position in order to operate. All reports require a key that will access the **X** or **Z** position.

X Reports

System reports are divided into two basic categories:

- **X** reports, which read totals without resetting
- **Z** reports, which read totals and reset them to zero

Most reports are available in both categories. Some reports, such as the Cash-in-Drawer report and the From-To PLU report are available only as **X** reports.

Some reports also provide identical but separate *period to date* reports. These reports maintain a separate set of totals which may be allowed to accumulate over a period of days, weeks, months, or even years. **X2** reports read period to date totals without resetting, and **Z2** reports read period to date totals and reset them to zero. Period to date totals are updated each time a **Z1** report is completed.

A complete list of available reports is presented in a chart on the following page.

An example is given for each of these reports in the pages that follow. Those reports which may be optionally abbreviated through register programming are represented twice. They are first shown with the option off, giving all totals, and again with the option turned on, showing the abbreviated version of the same report.

Registers programmed with pop-up clerks must be signed on in the **REG** control lock position prior to taking reports.

Running a Report - General Instructions

1. Refer to the "Report Table" .
2. Select a report type and the report mode.
3. Turn the control lock to the position indicated.
4. Enter the key sequence for the report you have selected.

Report Table

Report Type	Report Number	Report Mode	Control Lock Position	Key Sequence
Financial	1	X	X	1 – SBTL
		Z	Z	1 – SBTL
		X2	X	201 – SBTL
		Z2	Z	201 – SBTL
Time	2	X	X	2 – SBTL
		Z	Z	2 – SBTL
		X2	X	202 – SBTL
		Z2	Z	202 – SBTL
All PLU	3	X	X	3 – SBTL
		Z	Z	3 – SBTL
		X2	X	203 – SBTL
		Z2	Z	203 – SBTL
All Clerk	4	X	X	4 – SBTL
		Z	Z	4 – SBTL
		X2	X	204 – SBTL
		Z2	Z	204 – SBTL
Group	5	X	X	5 – SBTL
		Z	Z	5 – SBTL
		X2	X	205 – SBTL
		Z2	Z	205 – SBTL
All STOCK	6	X	X	6 – SBTL
		Z	Z	6 – SBTL
Daily Sales	8	X2	X	208 – SBTL
		Z2	Z	208 – SBTL
Individual Clerk Report	9	X	X	9-SBITL-#-CLERK-#-CLERK
		X2	X	209-SBITL-#-CLERK-#-CLERK
Open Table	11	X	X	11 – SBTL
		Z	Z	11 – SBTL
From/To PLU		X	X	13-SBTL XXXX – PLU – XXXX – PLU
		X2	X	213-SBTL XXXX – PLU – XXXX – PLU
From/To STOCK DRAWER TOTAL		X	X	14-SBTL XXXX –PLU – XXXX – PLU
		X	X	111-SBTL

Cash Declaration

If compulsory cash declaration is required, you must declare the count of the cash drawer prior to taking **X** or **Z** financial and clerk reports.

You can enter the cash drawer total in one step, or to facilitate the counting of the cash drawer, you can enter each type of bill/coin and checks separately and let the register act as an adding machine. You can also use the **X/TIME** key to multiply the denomination of currency times your count.

Either way you choose to enter cash, the register will compare your declaration with the expected cash and check in drawer totals and print the over or short amounts on the report.

For example:

1. Turn the control lock to the **X** or **Z** position (depending upon the type of report you are taking.)

2. Press the **CASH** key.

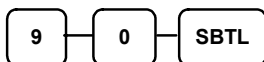

3. Enter the total of cash.

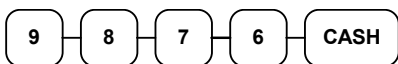

4. Enter the total of checks.

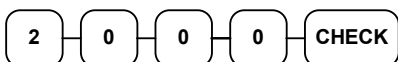

5. Press the **CASH** key to total the declaration.



DATE 01/15/2002 WED TIME 03:15
*** CASH DECLARATION ***
C A S H €98.76
C H E C K €20.00
INPUT AMT €118.76
DRAWER TTL €118.76
DIFFERENCE €0.00
CLERK 1 No.000001 00000

Service Mode Programming

Overview

The following procedures are done from the Service Mode menu:

- Clear all totals
- Clear grand total
- Clear PLU file
- EPROM Information
- Memory Allocation
- Assignment of functions to keyboard locations
- RS232C Port 1 & 2 Options

Memory Allocation Scan

1. Turn the control lock to the S position to scan the allocated memory .
2. Enter **60**, press the **SBTL** key.

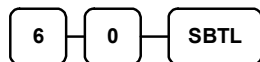

3. Press CASH key



Pc Online Mode

In ER-5200 series, there are no special commands to enter PC Online Mode.
When you want to enter PC Online mode, all you have to do is to set 232 Communication Option in Programming.
When PC sends commands to ECR, The ECR will be automatically Online Mode if connected.

Pc Memory Allocation

1. Turn the control lock to the S position.
2. To Allocate Memory, enter **60**, press the **SBTL** key.

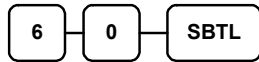

3. Refer to the chart below. Enter the index number and press the **X/TIME** key.

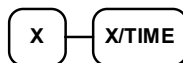

X	MEMORY ITEM
1	PLU
2	CLERK
3	GROUP
4	CHECK#
5	SOFT CHECK LINE
6	CHECK TYPE : Hard(1), Soft(0)
7	PRICE LEVEL
8	MIX AND MATCH

4. Enter the Number to allocate for the Memory Item and Press **CASH** key.
See the example data table below

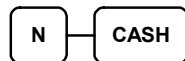

MEMORY ITEM	N
PLU	1000 (Max.10000)
CLERK	15 (Max. 99)
GROUP	20 (Max. 99)
CHECK #	20 (Max. 500)
SOFT CHECK LINE	30 (Max. 50)
CHECK TYPE	0(Soft Check), 1(Hard Check)
PRICE LEVEL	1 (Max. 2)
MIX AND MATCH	20 (Max. 100)

Default Memory Allocation

5. If you want to finish memory allocation, Enter **CASH** key with no numeric key input. And If you want to allocate Another memory area, Repeat 3,4 STEP.

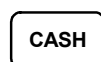

Clear Total

1. Turn the control lock to the S position.
2. To Reset Total, enter **20**, press the **SBTL** key.

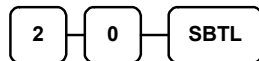

Clear Grand Total

1. Turn the control lock to the S position.
2. To Reset Grand Total, enter **30**, press the **SBTL** key.

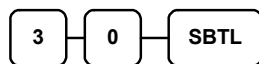

Clear PLU File

1. Turn the control lock to the S position.
2. To Reset PLU file, enter **40**, press the **SBTL** key.

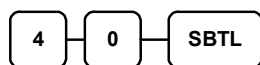

Eprom Information

1. Turn the control lock to the S position.
2. To Scan Eprom Information, enter **50**, press the **SBTL** key.

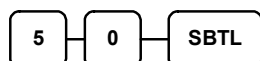

Function Key Assignment Programming

Function keys may be relocated, inactivated or changed with this program. For example, you may wish to place functions, such as **PREVIOUS BALANCE** and **SERVICE**, that are not placed on the default keyboard. Or perhaps, you may wish to remove a function, such as **CANCEL**, for security reasons.

Please note the following limitations:

- If you assign a duplicate of a function code, the duplicate will function exactly as the original - you will not get separate totals and counters on reports for the duplicated key.
- You can reassign keys only in locations that are programmable. See "Keyboards", where the key locations that may be programmed are identified.

To Assign a Function Key to a Location:

1. Turn the control lock to the **S** position.
2. Enter 70, press the **SBTL** key.

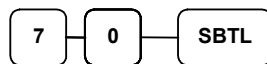

3. Refer to Function Key Codes to find the code for the key you wish to assign, press the location you wish to program. Repeat this step to assign another key.

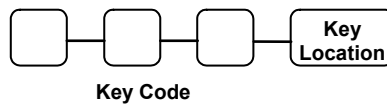

4. Press **CASH** key to finalize key assignment program.



Function Key Codes

Code	Function	Code	Function	Code	Function	Code	Function
1	NLU 1	144	CHARGE 3	170	MACRO 1	196	SBTL
117	NLU 117	145	CHARGE 4	171	MACRO 2	197	SCALE
120	Numeric 1	146	CHARGE 5	172	MACRO 3	198	SERVICE
121	Numeric 2	147	CHARGE 6	173	MACRO 4	199	TABLE #
122	Numeric 3	148	CHARGE 7	174	MACRO 5	200	TARE
123	Numeric 4	149	CHARGE 8	175	MACRO 6	201	TAKE OUT
124	Numeric 5	150	CHECK CASHING	176	MACRO 7	202	TAX EXEMPT
125	Numeric 6	151	ENDORSE	177	MACRO 8	203	TAX 1
126	Numeric 7	152	CHECK TEND	178	MACRO 9	204	TAX 2
127	Numeric 8	153	CHECK #	179	MACRO 10	205	TAX 3
128	Numeric 9	154	CLEAR (ESC)	180	RETURN	206	TAX 4
129	Numeric 0	155	CLERK #	181	MOD 1	207	TIP
130	Numeric 00	156	CURR. CONV. 1	182	MOD 2	208	VOID
131	DECIMAL	157	CURR. CONV. 2	183	MOD 3	209	WASTE
132	#/NS	158	CURR. CONV. 3	184	MOD 4	210	VALIDATION
133	%1	159	CURR. CONV. 4	185	MOD 5	211	PAYMENT
134	%2	160	DRIVE THRU	186	P/BAL	212	RCTP ON/OFF
135	%3	161	EAT-IN	187	PAID OUT 1	213	DETAIL FEED
136	%4	162	ERR CORRECT	188	PAID OUT 2	214	INACTIVE
137	%5	163	F/S SHIFT	189	PAID OUT 3	215	NON ADD
138	XTIME	164	F/S SUB	190	RECEIPT FEED		
139	ADD CHECK	165	F/S TEND	191	PRINT CHECK		
140	CANCEL	166	GUEST	192	PROMO		
141	CASH	167	PLU	193	REC ON ACCT 1		
142	CHARGE 1	168	LEVEL 1	194	REC ON ACCT 2		
143	CHARGE 2	169	LEVEL 2	195	REC ON ACCT 3		

RS232C Port 1/RS232C Port 2 Options

Turn the control lock to the S position

To program PORT1 enter **80** and press **SBTL** key.

To program PORT2 enter **81** and press **SBTL** key.

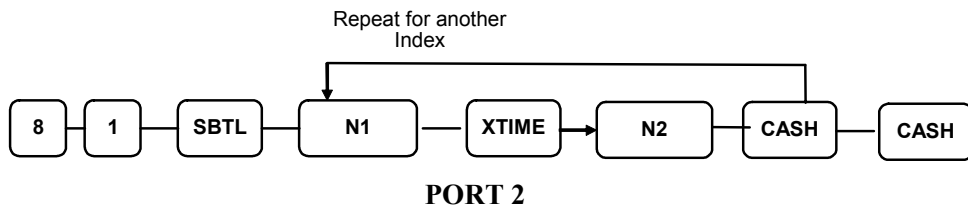
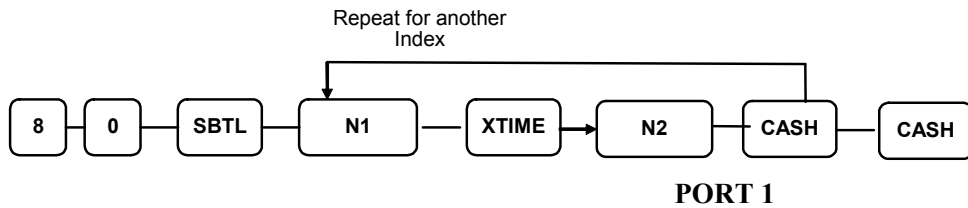

N	OPTION	N2	VALUE
1	Baud Rate	0	9600 BPS
		1	1200 BPS
		2	2400 BPS
		3	4800 BPS
		4	19200 BPS
2	Parity	0	NONE
		1	ODD
		2	EVEN
3	Data Bits	0	8 BITS
		1	7 BITS
4	Stop Bits	0	1 BIT
		1	2 BIT
5	Device Function	0	NONE
		1	PC
		2	SCALE
		4	RECEIPT PRINTER
		6	SCANNER
		7	COIN

N	OPTION	N2	VALUE
		8	EFT
		9	POLE
6	Initial Feeding Line KP	0 - 20	
7	End Feeding Line KP	0 - 20	
8	Initial Feeding Line Slip	0 - 20	
9	Print Line On Guest Check	0 - 50	
10	Scale Type	0	NCI
		1	CAS
11	Printer Type	0	NONE
		1	SAMSUNG SRP-100
		2	SRP-250
		3	SRP-300
		4	SRP-350
		5	CITIZEN3550
		6	CITIZEN810
		7	CITIZEN230
		8	EPSON TMT88-2
		9	EPSON U200
		10	EPSON U295
		11	EPSON U300
		12	EPSON U325
		13	EPSON U375
		14	STAR SP-200
		15	STAR SP-298
		16	STAR SP-300
17	STAR TSP-200		
12	Pole Display	0	EPSON
		1	ICD
13	EFT TYPE	0	EFT GLED
		1	EFT INGE
		2	EFT ZVT700
14	EFT CONFIG BYTE	0 - 127	
15	EFT CURRENCY	0	NONE
		1	DM
		2	EURO
16	EFT PASSWORD	0- 99999999	

Program Mode Programming

Default Programming

- All keyboard PLUs are nontaxable and open, without entry limits by default status programming of "00000000".
- All system options are set to **0** in default programming, unless otherwise noted. Change only the options which will deviate from default programming. There is no need to re-enter an option status of **0**, since **0** is its original setting.
- All programming (unless otherwise noted) is done with the control lock in the **P** position. Each section details a specific area of register programming.

Descriptor Programming Methods

Descriptors are programmable for PLUs, function keys, groups, clerks and the logo/messages. There are two methods available to program descriptors, the *Program Overlay Method* and the *Descriptor Code Method*.

This chapter describes both methods. ER5200/40 Use Overlay Method by default and ER5215 Use Descriptor Code method by default. You can select each method by System option programming.

Descriptor Code Method

If you customize your keyboard by covering key locations, or by installing double or quad size keys, you will need to program descriptors using the descriptor code method.

Descriptor Code Chart

CHAR	Ç	ü	é	â	ä	à	á	ç	ê	ë
CODE	001	002	003	004	005	006	007	008	009	010
CHAR	è	ï	î	ì	Ä	Å	É	æ	Æ	ô
CODE	011	012	013	014	015	016	017	018	019	020
CHAR	ö	ò	û	ù	ÿ	Ö	Ü	ø	£	¥
CODE	021	022	023	024	0250	026	027	028	029	030
CHAR	€	SPACE	!	"	#	\$	%	&	'	(
CODE	031	032	033	034	035	036	037	038	039	040
CHAR)	*	+	,	-	.	/	0	1	2
CODE	041	042	043	044	045	046	047	048	049	050
CHAR	3	4	5	6	7	8	9	:	;	<
CODE	051	052	053	054	055	056	057	058	059	060
CHAR	=	>	?	@	A	B	C	D	E	F
CODE	061	062	063	064	065	066	067	068	069	070
CHAR	G	H	I	J	K	L	M	N	O	P
CODE	071	072	073	074	075	076	077	078	079	080
CHAR	Q	R	S	T	U	V	W	X	Y	Z
CODE	081	082	083	084	085	086	087	088	089	090
CHAR							a	b	c	d
CODE	091	092	093	094	095	096	097	098	099	100
CHAR	e	f	g	h	I	j	k	l	m	n
CODE	101	102	103	104	105	106	107	108	109	110
CHAR	o	p	q	r	s	t	u	v	w	x
CODE	111	112	113	114	115	116	117	118	119	120
CHAR	y	z	BACK SPACE			Double				
CODE	121	122	123			999				

Tax Programming

The ER-5200/40/15 has the capability to support four separate taxes.

Taxes can be calculated as either a straight percentage rate of between .001% and 99.999%, or a 60 break point tax table. Each tax may be either an add-on tax (added to the cost of a taxable item), or a value added tax (VAT) that is included in the price of the item.

Tax rate 4 may be set to function as the Canadian Goods & Services Tax (GST). Definitions for tax rates 1, 2, 3 & 4 are made as part of tax programming.

- If you are entering a tax rate (add-on or VAT), see "Straight Percentage Tax Rate Programming" to enter the percentage rate.
- If you are entering a Canadian Goods and Services Tax (GST), use tax rate 4 for the GST tax, and use tax rates 1, 2 and/or 3 for any other provincial tax or taxes. See "Straight Percentage Tax Rate Programming" to enter the GST status and percentage rate.

Important Note: After you have entered your tax program(s), test for accuracy by entering several transactions of different dollar amounts. Carefully check to make sure the tax charged by the cash register matches the tax on the printed tax chart for your area. As a merchant, you are responsible for accurate tax collection. If the cash register is not calculating tax accurately, contact your dealer for assistance.

Descriptor

- Refer to "Program 80 – Function Key Descriptor"

Straight Percentage Tax Rate Programming

When tax requirements may be met using a straight percentage rate, use the following method to program a tax as a straight percentage.

Programming Straight Percentage Tax Rates and Status

1. Turn the control lock to the **P** position.
2. If the tax is a percentage rate, with a decimal. (0.000-99.999). It is not necessary to enter preceding zeros. For example, for 6%, enter 06.000 or 6.000.
3. For the type of tax:

If the tax is a percentage added to the sale (normal add on tax), enter:	0
If the tax is a percentage value added tax (VAT; calculated as part of the sale), enter:	2

- Enter **0** here for all taxes, unless if you are programming tax 4 as a Canadian GST. If tax 4 is a Canadian GST, enter the sum of the options below:

OPTION	VALUE	=	SUM
GST (tax 4) is taxable by rate 1?	Yes = 1 No = 0		
GST (tax 4) is taxable by rate 2?	Yes = 2 No = 0		
GST (tax 4) is taxable by rate 3?	Yes = 4 No = 0		

- Press the **TAX** key for the tax you are programming.
- Press the **CASH** key to end programming.

Tax Rate Programming Flowchart

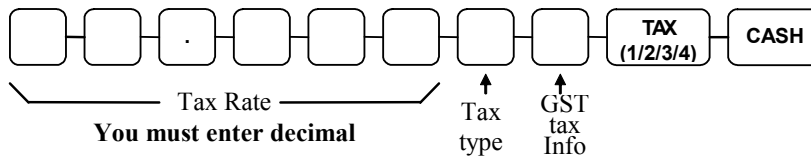

PLU Programming

All PLUs, whether they are registered by pressing a PLU key on the keyboard, or by entering the PLU number and pressing the **PLU** key, have the same programming options. These options are set through separate programs:

- Program 100 – PLU Status Programming determines whether the PLU is open, preset or inactive. Also selected here are tax, food stamp, scale, negative, single item, hash, gallonage, compulsory number entry, compulsory validation, compulsory condiment and print options.
- Program 110 – PLU Auto Tare Programming.
- Program 150 – PLU Group Assignment allows you to select up to two groups where each PLUs sales will accumulate.
- Program 200 - PLU Price/HALO Programming determines the PLU price if the PLU is preset, or the high amount lock out (HALO) if the PLU is open.
- Program 250 - PLU Stock Amount Programming allows you to add stock to the PLU sales counters for PLUs you have designated as stock keeping PLUs.
- Program 300 - PLU Description Programming allows you to set a unique, up to 18 character, descriptor for each PLU.
- Program 350 - PLU Link Programming allow you to link a PLU to another PLU, so that registration of the first PLU will automatically trigger registration of the linked PLU.
- Program 400 - PLU Delete Programming allows you to delete the PLU.
- Program 450 - PLU Mix & Match Programming.

Program 100 - PLU Status Programming

1. Turn the control lock to the **P** position.
2. To begin the program, enter **1 0 0**, press the **SBTL** key.

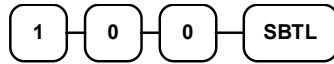

3. Select the PLU or PLUs you wish to program in one of the following ways:

- Press a PLU key on the keyboard, or



- Press the first PLU keys that are to receive the same status and Press the last PLU keys, or



- Enter up to 15 digit number of the PLU and press the **PLU** key, or

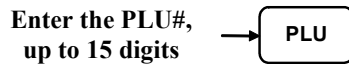

- Enter the number of the first PLU in a range of PLUs that are to receive the same setting; press the **PLU** key. Enter the last number in the range; press the **PLU** key.

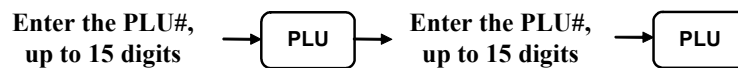

4. Refer to the "PLU Status Chart" to determine the values for **N1** through **N9**. (If an address offers more than one option, add the values for each option and enter the sum. For example, if you wish the PLU to be taxable by rates 1 and 3, add the values for your choices, 1 + 4, and enter the sum "5" for address N5.) Enter the values you have selected, press the **X/TIME** key. (**You do not need to enter preceding zeros**. For example, if you are only selecting a value for **N9**, i.e. auto tare by number 1, just enter **1**.)



5. To program additional PLUs, repeat from step 3, or press the **CASH** key to finalize the program.



PLU Status Chart

Address	Program Option	Value	=	Sum
N1	PLU is preset?	Yes = 0 No = 1		
	PLU is override preset ?	Yes = 0 No = 2		
	PLU is taxable by rate 1?	Yes = 4 No = 0		
N2	PLU is taxable by rate 2?	Yes = 1 No = 0		
	PLU is taxable by rate 3?	Yes = 2 No = 0		
	PLU is taxable by rate 4?	Yes = 4 No = 0		
N3	PLU is food stamp eligible?	Yes = 1 No = 0		
	PLU is negative item?	Yes = 2 No = 0		
	PLU is hash?	Yes = 4 No = 0		
N4	PLU is single item?	Yes = 1 No = 0		
	Compulsory non-add number?	Yes = 2 No = 0		
	PLU is gallonage?	Yes = 4 No = 0		
N5	PLU is inventory?	Yes = 1 No = 0		
	PLU is inactive?	Yes = 2 No = 0		
	PLU is scalable?	Yes = 4 No = 0		
N6	P.LU is auto-scale entry?	Yes = 1 No = 0		
	PLU is a condiment?	Yes = 2 No = 0		
	Compulsory condiment entry?	Yes = 4 No = 0		
N7	Print PLU on receipt?	Yes = 0 No = 1		
	Print PLU on detail?	Yes = 0 No = 2		
	Print PLU on check?	Yes = 0 No = 4		
N8	Print item's price on receipt?	Yes = 0 No = 1		
	Print item's price on check?	Yes = 0 No = 2		
	PLU is disabled PROMO function?	Yes = 4 No = 0		

Address	Program Option	Value	=	Sum
N9	PLU counter is not reset when a PLU Z report is done?	Yes = 1 No = 0		
	PLU is preset override in MGR control?	Yes = 2 No = 0		

Program 110 - PLU Auto Tare Programming

1. Turn the control lock to the **P** position.
2. To begin the program, enter **1 1 0**, press the **SBTL** key

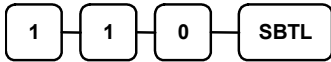

3. Select the PLU or PLUs you wish to program in one of the following ways:

Press on the keyboard, or



Press the first PLU keys that are to receive the same status and Press the last PLU keys,
or



Enter up to 15 digit number of the PLU and press the **PLU** key, or

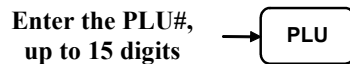

Enter the number of the first PLU in a range of PLUs that are to receive the same setting; press the **PLU** key. Enter the last number in the range; press the **PLU** key.

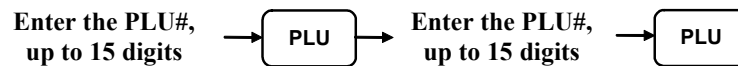

4. Enter a value(1-5) to indicate the number of the preprogrammed tare weight you want to automatically subtract when the PLU is used for scale entry (using an optional scale). Enter 0 to disable automatic tare subtraction.

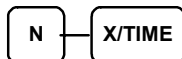

5. program additional PLUs, repeat from step 3, or press the **CASH** key to finalize the program



Program 150 - PLU Group Assignment

Each PLU may report to any three of 20 groups. Group totals appear on reports, so that you can track sales of different types of items. A group can also be used to designate items that are to print on an optional kitchen printer.

Note: The PLU will report to group "0", if not programmed to report to groups 1-20.

1. Turn the control lock to the **P** position.
2. To begin the program, enter **1 5 0**, press the **SBTL** key.



3. Select the PLU or PLUs you wish to program in one of the following ways:

- Press a PLU key on the keyboard, or



- Press the first PLU keys that are to receive the same status and Press the last PLU keys, or



- Enter up to 15 digit number of the PLU and press the **PLU** key, or

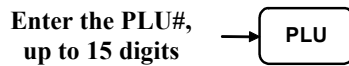

- Enter the number of the first PLU in a range of PLUs that are to receive the same setting; press the **PLU** key. Enter the last number in the range; press the **PLU** key.

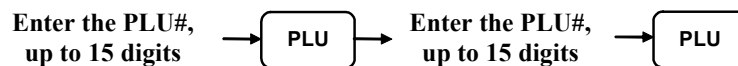

4. Enter up to three 2-digit numbers representing the groups where you wish to add the PLUs sales, i.e. enter **1 0** for group 10 or enter **0 4** for group four. Press the **X/TIME** key.

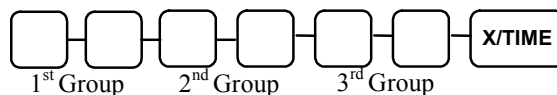

5. To program additional PLUs, repeat from step 3, or press the **CASH** key to finalize the program.



Program 200 - PLU Price/HALO Programming

If a PLU is open, set the HALO (high amount lock out) here. If a PLU is preset set the preset price here. If a PLU is set with gallonage status, enter the price per gallon here. (Enter price per gallon in tenths of a penny, i.e. 1299 for €1.29 9/10 per gallon.)

1. Turn the control lock to the **P** position.
2. To begin the program, enter **2 0 0**, press the **SBTL** key.

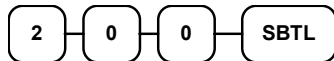

3. Select the PLU or PLUs you wish to program in one of the following ways:

- Press a PLU key on the keyboard, or



- Press the first PLU keys that are to receive the same status and Press the last PLU keys, or



- Enter up to 15 digit number of the PLU and press the **PLU** key, or

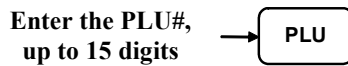

- Enter the number of the first PLU in a range of PLUs that are to receive the same setting; press the **PLU** key. Enter the last number in the range; press the **PLU** key.

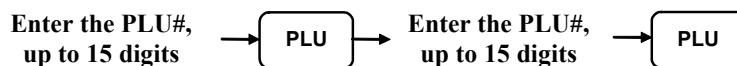

4. If the PLU is open, enter a HALO of up to 7 digits. If the PLU is preset, enter a preset price.



Price/HALO

If the PLU Price Level is 2, Repeat this again..



Price/HALO

5. To program additional PLUs, repeat from step 3, or press the **CASH** key to finalize the program.



Program 250 - PLU Stock Amount Programming

With this program, you can add stock to the PLU sales counters for PLUs you have designated as stock keeping PLUs. See "Program 100 – PLU Status Programming". The stock number set here can be the amount of stock that is being added to the current level, or optionally, it can be the new total stock level. See option #18 in "System Option Programming" to set this option.

1. Turn the control lock to the **P** position.
2. To begin the program, enter **2 5 0**, press the **SBTL** key.

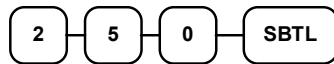

3. Select the PLU or PLUs you wish to program in one of the following ways:

- Press a PLU key on the keyboard, or



- Press the first PLU keys that are to receive the same status and Press the last PLU keys, or



- Enter up to 15 digit number of the PLU and press the **PLU** key, or

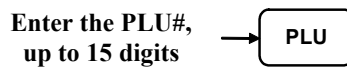

- Enter the number of the first PLU in a range of PLUs that are to receive the same setting; press the **PLU** key. Enter the last number in the range; press the **PLU** key.

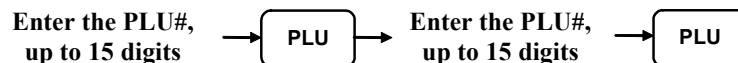

4. Enter the stock amount you wish to add (up to six digits), press the **X/TIME** key.



Stock Amount

5. To program additional PLUs, repeat from step 3, or press the **CASH** key to finalize the program.



Program 300 - PLU Description Programming

Program descriptors by typing descriptors on the alpha keyboard overlay or by entering three digit alpha character codes. To describe by three digit alpha character codes you must select 'No' in system option #25(See "System Option Programming").

1. Turn the control lock to the **P** position
2. To begin the program, enter **3 0 0**, press the **SBTL** key.

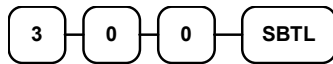

3. Select the PLU you wish to program in one of the following ways:

- Press a PLU key on the keyboard, or



- Enter up to 15 digit number of the PLU and press the **PLU** key, or

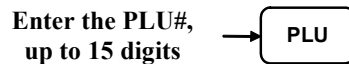

4. If you are programming

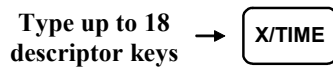

or,

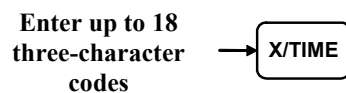

5. To program additional PLUs, repeat from step 3, or press the **CASH** key to finalize the program.



Program 350 - PLU Link Programming

PLU link programming allows you to link a PLU to another PLU, so that registration of the first PLU will automatically trigger registration of the linked PLU. For example, you may wish to link a bottle deposit with the sale of beverages, or you may wish to register a group of items normally sold together.

1. Turn the control lock to the **P** position.
2. To begin the program, enter **3 5 0**, press the **SBTL** key.

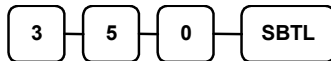

3. Select the PLU you wish to program in one of the following ways:

- Press a PLU key on the keyboard, or



- Enter up to 15 digit number of the PLU and press the **PLU** key, or

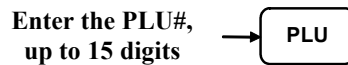

4. Enter the number of the PLU you wish the PLU linked to; press the PLU key. Or press the PLU key on the keyboard you wish the PLU linked to.



If you want to unlink,



5. To program additional PLUs, repeat from step 3, or press the **CASH** key to finalize the program.

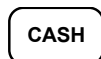

Program 400 – PLU Delete Programming

NOTE: To delete a PLU, all totals for the PLU must be cleared from Z reports(including Stock and PLU reports.)

1. Turn the control lock to the **P** position.
2. To begin the program, enter **4 0 0**, press the **SBTL** key.

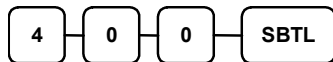

3. Select the PLU or PLUs you wish to program in one of the following ways:

- Press a PLU key on the keyboard, or



- Press the first PLU keys that are to delete and Press the last PLU keys, or



- Enter up to 15 digit number of the PLU and press the **PLU** key, or

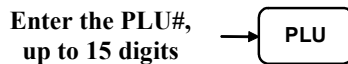

- Enter the number of the first PLU in a range you wish to delete and press the **PLU** key. Enter the last number in the range; press the **PLU** key.

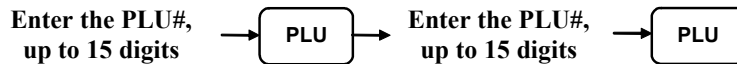

4. Press X/TIME key.



5. To program additional PLUs, repeat from step 3, or press the **CASH** key to finalize the program.



Program 450 - PLU MIX & MATCH Programming

1. Turn the control lock to the **P** position.
2. To begin the program, enter **4 5 0**, press the **SBTL** key.

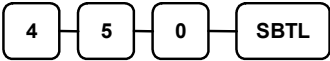

3. Select the PLU you wish to program in one of the following ways:
 - Press a PLU key on the keyboard, or



- Press the first PLU keys that are to delete and Press the last PLU keys, or



- Enter up to 15 digit number of the PLU and press the **PLU** key, or

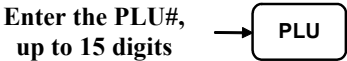

- Enter the number of the first PLU in a range you wish to delete and press the **PLU** key. Enter the last number in the range; press the **PLU** key.

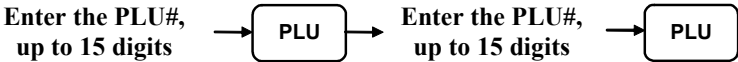

4. Enter the number of the Mix & Match Table(1-20); press the **X/TIME** key.



5. To program additional PLUs, repeat from step 3, or press the **CASH** key to finalize the program.



System Option Programming

Refer to the “System Option Table” to review the system options. Read each option carefully to determine if you wish to make any changes.

NOTE: Because after clearing memory all options settings are automatically set to 0, and because your most likely option selections require a status setting of 0, you do not need to program this section unless you wish to change the default status.

Programming a System Option:

1. Turn the control lock to the **P** position.
2. Enter **3 0**, press the **SBTL** key.
3. Enter a system option address, press the **X/TIME** key.
4. Enter the number representing the status you have selected, or if there is more than one decision to be made in an address, add the values representing your choices for each decision and enter the sum. Press the **SBTL** key.
5. Repeat from step 3 for each system option you wish to change.
6. Press the **CASH** key to end system option programming.

System Option Flowchart

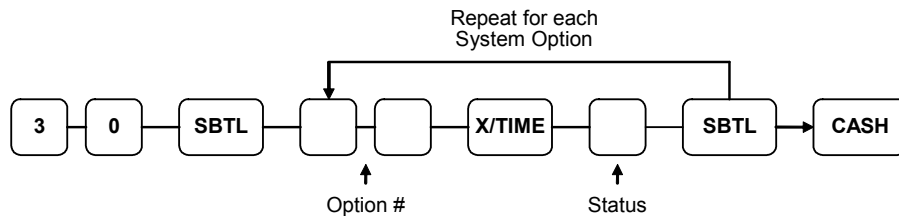

System Option Table

Address	SYSTEM OPTION	VALUE	=	SUM
1	Beeper is active?	Yes = 0 No = 1		
	Clerk operation is real clerk key?	Yes = 2 No = 0		
2	Clerk sign on method is:	direct entry =	0	
		code entry =	1	
3	Clerks are:	pop-up =	1	
		stay down =	0	
4	Drawer needs to be shut to operate?	Yes = 0 No = 1		
	Activate open Drawer Alarm?	Yes = 2 No = 0		
5	The number of seconds before the open drawer warning tone sounds (default is 30 seconds).	1-99		
6	Allow the post tender function?	Yes = 1 No = 0		
	Open drawer on post tender?	Yes = 0 No = 2		
	Allow multiple receipts?	Yes = 4 No = 0		
7	Cash Declaration Required before Z Financial report?	Yes = 1 No = 0		
	Allow negative balance sales in the X control lock position only?	Yes = 2 No = 0		
8	Allow zero balance sales in the X control lock position only?	Yes = 1 No = 0		
	Consecutive number is reset after a financial report?	Yes = 2 No = 0		
9	Reset Grand Total after Z financial Report?	Yes = 1 No = 0		
	Cash drawer will open when reports are run?	Yes = 0 No = 2		
	Open drawer during training mode?	Yes = 0 No = 4		
10	Decimal place : (0,1,2,3) default=2	0-3		
11	Date format is:	MMDDYY =	0(default)	
		DDMMYY =	1	
		YYMMDD =	2	

Address	SYSTEM OPTION		VALUE	=	SUM
12	Percentage and Tax calculations will:	round up at 0.005 =	0(default)		
		always round up =	1		
		always round down =	2		
13	Split price calculations will:	round up at 0.005 =	0(default)		
		always round up =	1		
		always round down =	2		
14	Compulsory Eat in T-out D-thru before tendering?		Yes = 1 No = 0		
	Hash is	normal =	0		
		non-add =	2		
15	Reset the Financial report Z counter after a Z1 Financial report?		Yes = 1 No = 0		
	Reset the Time report Z counter after a Z1 Time report?		Yes = 2 No = 0		
	Reset the PLU report Z counter after a Z1 PLU report?		Yes = 4 No = 0		
16	Reset the Clerk report Z counter after a Z1 Clerk report?		Yes = 1 No = 0		
	Reset the Group report Z counter after a Z1 Group report?		Yes = 2 No = 0		
17	Reset the Daily sale report Z counter after a Z2 Daily sale report?		Yes = 1 No = 0		
	Paper sensor is enabled?		Yes = 0 No = 2		
	Deactivate Split Pricing?		Yes = 4 No = 0		
18	Allow Direct Multiply?		Yes = 1 No = 0		
	Inventory (stock) counter programming	added to current level =	2		
		counter replaces current level =	0		
19	The number of numeric digits: 0 is no limit		0-14		

Address	SYSTEM OPTION		VALUE	=	SUM
20	Direct multiply more than one digit?		Yes = 1 No = 0		
	Tender Validation amount is:	amount tendered =	2		
		amount of sale =	0		
21	Display add price of linked item?		Yes = 1 No = 0		
	Allow sale when stock reaches "0"?		Yes = 0 No = 2		
	Allow Australian round on subtotal?		Yes = 4 No = 0		
22	Allow Australian round on cash?		Yes = 1 No = 0		
	Allow Z stock report?		Yes = 0 No = 2		
23	Training mode	enter =	1		
		exit =	0		
24	Activate autocutter?		Yes = 1 No = 0		
25	Descriptor entry Method is Overlay.	ER5200/40 Keyboard overlay=	0		
		Character code =	1		
		ER-5215	No(Fixed)		
	Should % keys affect NET sale?		Yes = 0 No = 2		
	Disable Cash Declaration?		Yes = 4 No = 0		
26	Table Management =		0		
	Clerk Interrupt =		1		
	VAT shift affect the whole receipt?		Yes = 2 No = 0		
	Not count in memory in void mode?		Yes = 4 No = 0		
27	Disable level keys:	Level1 =	1		
		Level2 =	2		
28	Price level is:	Pop-up after item =	0		
		Pop-up after sale =	1		
		Stay-down =	2		
29	Modifier is:	Pop-up after item =	0		
		Pop-up after sale =	1		
		Stay-down =	2		

Print Option Programming

Refer to the “Print Option Table” to review the print options. Read each option carefully to determine if you wish to make any changes.

NOTE: Because after clearing memory all options settings are automatically set to 0, and because your most likely option selections require a status setting of 0, you do not need to program this section unless you wish to change the default status.

Programming a Print Option:

1. Turn the control lock to the **P** position.
2. Enter **4 0**, press the **SBTL** key.
3. Enter a print option address, press the **X/TIME** key.
4. Enter the number representing the status you have selected, or if there is more than one decision to be made in an address, add the values representing your choices for each decision and enter the sum. Press the **SBTL** key.
5. Repeat from step 3 for each print option you wish to change.
6. Press the **CASH** key to end print option programming.

Print Option Flowchart

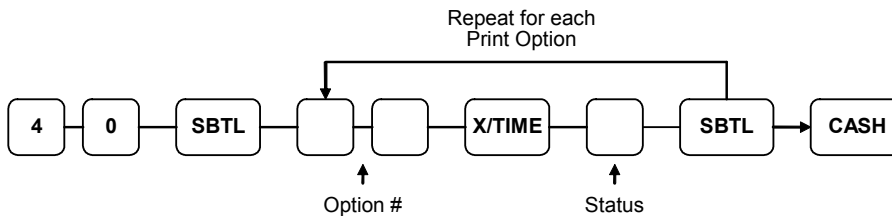

Print Option Table

Address	PRINT OPTION	VALUE	=	SUM
1	Print media total on clerk report?	Yes = 1 No = 0		
	Print tax symbol?	Yes = 0 No = 2		
2	Void/Return totals will print on the Financial report?	Yes = 0 No = 1		
	Audaction total will print on the Financial report?	Yes = 2 No = 0		
3	Skip media totals with zero activity on the Financial report?	Yes = 0 No = 1		
	Skip media totals with zero activity on the Clerk report?	Yes = 0 No = 2		
	Print Clerk report at the end of the Financial report?	Yes = 4 No = 0		
4	Print PLU sale item number?	Yes = 1 No = 0		
	Print PLU with zero totals on report?	Yes = 2 No = 0		
	Subtotal is printed when the SBTL key is pressed?	Yes = 4 No = 0		
5	Print percentage of sales on the PLU report?	Yes = 1 No = 0		
	Print consecutive number counter on receipt?	Yes = 0 No = 2		
6	Print date on receipt?	Yes = 0 No = 1		
	Print time on receipt?	Yes = 0 No = 2		
	Print machine number on receipt?	Yes = 0 No = 4		
7	Print clerk name on receipt?	Yes = 0 No = 1		
	Print Z counter on reports?	Yes = 0 No = 2		
8	Home Currency symbol (see note1 below)	€ (default)		
9	Print receipt when sign on/off?	Yes = 0 No = 1		
	Print Grand total on the X Financial report?	Yes = 0 No = 2		
	Print Grand total on the Z Financial report?	Yes = 0 No = 4		
10	Print Gross total on the X Financial report?	Yes = 0 No = 1		

Address	PRINT OPTION	VALUE	=	SUM
	Print Gross total on the Z Financial report?	Yes = 0 No = 2		
11	Print the subtotal without tax on the receipt?	Yes = 1 No = 0		
	Tax amount to print on receipt is:	combine = itemize =	2 0	
12	Print the tax amount on receipt?	Yes = 0 No = 1		
	Print taxable totals?	Yes = 2 No = 0		
	Print the tax rate?	Yes = 4 No = 0		
13	Print a breakdown of the VAT eligible sale?	Yes = 1 No = 0		
	Print training mode message on the receipt during training mode operations?	Yes = 2 No = 0		
14	Currency Symbol: (see note2 below)	CONV. #1 =	.	
15		CONV. #2 =	.	
16		CONV. #3 =	.	
17		CONV. #4 =	.	
18	Print the order number on receipt?	Yes = 0 No = 1		
	Print the item's price on the kitchen printer requisition?	Yes = 2 No = 0		
19	Print registrations in void mode on the kitchen printer requisition?	Yes = 0 No = 1		
	Print registrations in training mode on the kitchen printer requisition?	Yes = 2 No = 0		
20	Combine like items on the kitchen printer?	Yes = 0 No = 1		
	Consolidation of like items on check track?	Yes = 0 No = 2		
	Chooses volume unit When the PLU is gallonage.	gallons = liters =	0 4	
21	Print preamble message on receipt?	Yes = 0 No = 1		
	Print postamble message on receipt?	Yes = 0 No = 2		
	Print preamble message on the guest check?	Yes = 4 No = 0		
22	Print postamble message on the guest check?	Yes = 1 No = 0		

Address	PRINT OPTION	VALUE	=	SUM	
	Print pre/postamble message on the journal receipt?	Yes = 2 No = 0			
23	Print average items per customer on the Financial report?	Yes = 0 No = 1			
	Print average sales per customer on the Financial report?	Yes = 0 No = 2			
24	Issue a second receipt for the same transaction?	Yes = 1 No = 0			
	Priority print by group on the kitchen printer?	Yes = 2 No = 0			
	Print the PLU number and descriptor on the receipt?	Yes = 4 No = 0			
25	Do not print when polling reports?	Yes = 1 No = 0			
	Print PLU# on PLU report?	Yes = 2 No = 0			
	Grand total is:	net sale =	4		
		gross sale =	0		
26	Print journal font	small =	0		
		normal =	1		
	Print journal reverse?	Yes = 2 No = 0			
	Journal print is off?	Yes = 4 No = 0			
27	Send order to the kitchen printer when the SBTL key is pressed?	Yes = 1 No = 0			
	Print date on hard check?	Yes = 2 No = 0			
	Print round amount on the kitchen printer?	Yes = 4 No = 0			
28	Pre Print graphic logo on receipt?	Yes = 1 No = 0			
	Post Print graphic logo on receipt?	Yes = 2 No = 0			
29	Pre Print graphic logo on the guest check?	Yes = 1 No = 0			
	Post Print graphic logo on the guest check?	Yes = 2 No = 0			
30	Print pre- logo	Default =	0		
		User =	1		
	Print post- logo	Default =	0		
		User =	2		
31	Number of Pre-feeding lines. (Only valid when	0-5			

Address	PRINT OPTION	VALUE	=	SUM
	Autocutter is activated System Option 24)			
32	Number of Post-feeding lines. (Only valid when Autocutter is activated System Option 24)	0-5		

NOTE 1: Print Option# 8 - Users outside of the USA can designate a different currency symbol. To select a different symbol, type descriptors on the alpha keyboard overlay or enter three digit alpha character codes. To describe by three digit alpha character codes you must select 'No' in system option #25 Overlay Descriptor (See "System Option Programming").

NOTE 2: Print Option# 14,15,16,17 - If you are using the currency conversion feature, you can select the appropriate symbol for each foreign currency you are accepting. To select a different symbol, type descriptors on the alpha keyboard overlay or enter three digit alpha character codes. To describe by three digit alpha character codes you must select 'No' in system option #25 Overlay Descriptor(See "System Option Programming").

Function Key Programming

Three programs are used to program function keys;

- *Program 70* - is used to set each keys individual options
- *Program 80* - is used to program a 18 character alpha numeric descriptor
- *Program 90* - is used to set a high amount limit (HALO)

In this chapter you will find:

- General instructions for programs 70, 80 and 90.
- Specific programming instructions for each function key.

Program 70 - Function Key Options

Use Program 70 to set options for function keys. Because of the differences inherent in function keys, individual options will be different. See the specific instructions for each key in this chapter to find the options for each key.

1. Turn the control lock to the **P** position.
2. To begin the program, enter **7 0**, press the **SBTL** key.

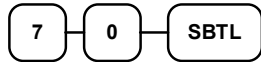

3. Enter the values for the option digit or digits. Depending on the function key you are programming, you may enter up to six digits **N1** through **N6**. Determine the values for **N1** through **N6** by referring to the specific function key information that follows. (**You do not need to enter preceding zeros.** For example, if the function key offers six digits, **N1** through **N6** and you are only selecting a value for **N6**, just enter the value for **N6**.) Press the function key you wish to program.

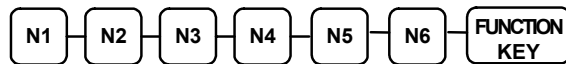

4. To program additional function keys, repeat from step 3, or press the **CASH** key to finalize the program.



Program 80 - Function Key Descriptor

Program descriptors by typing descriptors on the alpha keyboard overlay or by entering three digit alpha character codes. To describe by three digit alpha character codes you must select 'No' in system option #25(See "System Option Programming").

1. Turn the control lock to the **P** position.
2. To begin the program, enter **8 0**, press the **SBTL** key.

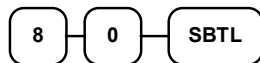

3. If you are programming ER-5200

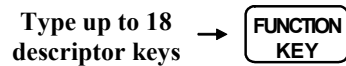

or,,

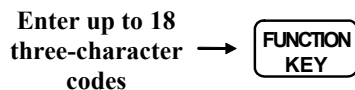

If you are programming ER-5240

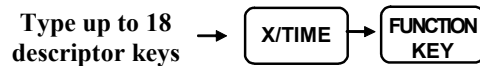

or,

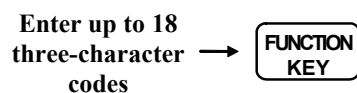

4. To program additional function keys, repeat from step 3, or press the **CASH** key to finalize the program.



Program 90 - Function Key HALO

Use Program 90 to program a high amount lock out (HALO) for a function key. Only specific keys require this program. For example, you can set a HALO for the **CASH**, **CHECK** or **CHARGE** keys. Refer to the specific function key programming information in this chapter to determine when the HALO option is available.

1. Turn the control lock to the **P** position.
2. To begin the program, enter **9 0**, press the **SBTL** key.

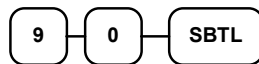

3. Enter a HALO of up to eight digits, (or "0" for no HALO).

**Enter 1-8 digit
HALO**

4. Press the function key on the keyboard you wish to program.



5. To program additional function keys, repeat from step 2, or press the **CASH** key to finalize the program.



ADD CHECK

Options - Program 70

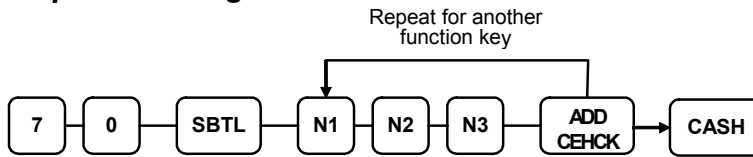

Address	OPTION	VALUE	=	SUM
N1	Key is inactive?	Yes = 1 No = 0		
	Compulsory before tendering?	Yes = 2 No = 0		
	Advance the consecutive # when this function is used?	Yes = 0 No = 4		
N2	Delete the pre/postamble when this function is used?	Yes = 0 No = 1		
	Exempt tax 1?	Yes = 2 No = 0		
	Exempt tax 2?	Yes = 4 No = 0		
N3	Exempt tax 3?	Yes = 1 No = 0		
	Exempt tax 4?	Yes = 2 No = 0		
	Validation is compulsory?	Yes = 4 No = 0		

Descriptor

- Refer to "Program 80 – Function Key Descriptor"

CANCEL

Options - Program 70

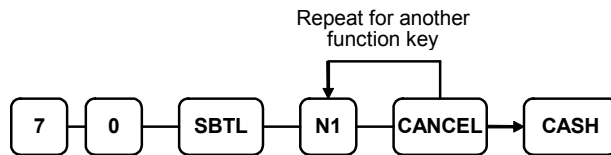

Address	OPTION	VALUE	=	SUM
N1	Key is inactive?	Yes = 1 No = 0		
	Key is active in X control lock position only?	Yes = 2 No = 0		
	Validation is compulsory?	Yes = 4 No = 0		

Descriptor

- Refer to "Program 80 – Function Key Descriptor"

HALO

- Refer to "Program 90 – Function Key HALO"

CASH

Options - Program 70

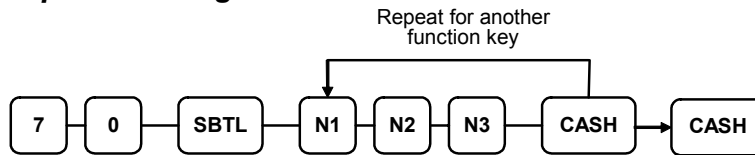

Address	OPTION	VALUE	=	SUM
N1	Amount tender is compulsory?	Yes = 1 No = 0		
	Allow over tendering and under tendering in X control lock position only?	Yes = 2 No = 0		
	Disable under tendering?	Yes = 4 No = 0		
N2	Open cash drawer?	Yes = 0 No = 1		
	Exempt tax 1?	Yes = 2 No = 0		
	Exempt tax 2?	Yes = 4 No = 0		
N3	Exempt tax 3?	Yes = 1 No = 0		
	Exempt tax 4?	Yes = 2 No = 0		
	Validation is compulsory?	Yes = 4 No = 0		

Descriptor

- Refer to "Program 80 – Function Key Descriptor"

HALO

- Refer to "Program 90 – Function Key HALO"

CHARGE1-8

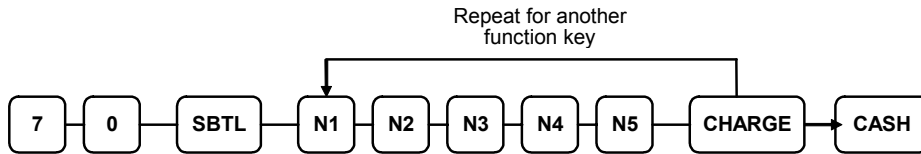

Address	OPTION	VALUE	=	SUM
N1	Amount tender is compulsory?	Yes = 1 No = 0		
	Allow over tendering and under tendering in X control lock position only?	Yes = 2 No = 0		
	Disable under tendering?	Yes = 4 No = 0		
N2	Open cash drawer?	Yes = 0 No = 1		
	Allow over tendering ?	Yes = 2 No = 0		
	Non-add # entry compulsory?	Yes = 4 No = 0		
N3	Exempt tax 1?	Yes = 1 No = 0		
	Exempt tax 2?	Yes = 2 No = 0		
	Exempt tax 3?	Yes = 4 No = 0		
N4	Exempt tax 4?	Yes = 1 No = 0		
	Validation compulsory?	Yes = 2 No = 0		
	Send to EFT?	Yes = 4 No = 0		
N5	EFT Code	0-8		

Descriptor

- Refer to “Program 80 – Function Key Descriptor”

HALO

- Refer to “Program 90 – Function Key HALO”

CHECK

Options - Program 70

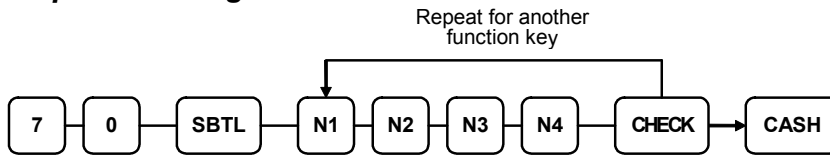

Address	OPTION	VALUE	=	SUM
N1	Amount tender is compulsory?	Yes = 1 No = 0		
	Allow over tendering and under tendering in X control lock position only?	Yes = 2 No = 0		
	Disable under tendering?	Yes = 4 No = 0		
N2	Open cash drawer?	Yes = 0 No = 1		
	Exempt tax 1?	Yes = 2 No = 0		
	Exempt tax 2?	Yes = 4 No = 0		
N3	Exempt tax 3?	Yes = 1 No = 0		
	Exempt tax 4?	Yes = 2 No = 0		
N4	Check endorsement compulsory?	Yes = 1 No = 0		
	Validation is compulsory?	Yes = 2 No = 0		

Descriptor

- Refer to "Program 80 – Function Key Descriptor"

HALO

- Refer to "Program 90 – Function Key HALO"

CHECK CASHING

Options - Program 70

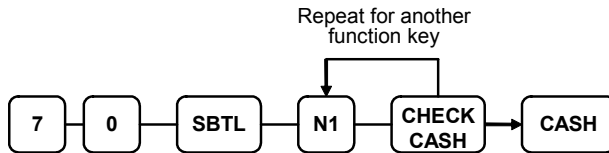

Address	OPTION	VALUE	=	SUM
N1	Key is inactive?	Yes = 1 No = 0		
	Key is active in X control lock position only?	Yes = 2 No = 0		
	Validation is compulsory?	Yes = 4 No = 0		

Descriptor

- Refer to "Program 80 – Function Key Descriptor"

HALO

- Refer to "Program 90 – Function Key HALO"

CHECK ENDORSEMENT

Options - Program 70

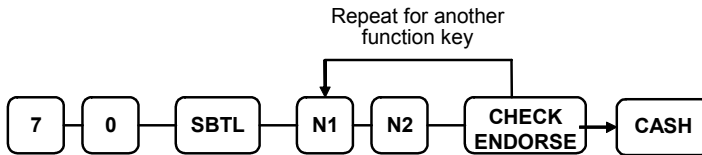

Address	OPTION	VALUE	=	SUM
N1	Key is inactive?	Yes = 1 No = 0		
	Print the amount of the check and endorsement message?	Yes = 2 No = 0		
	Print date?	Yes = 4 No = 0		
N2	Print time?	Yes = 1 No = 0		
	Print clerk?	Yes = 2 No = 0		
	Print consecutive number?	Yes = 4 No = 0		

Descriptor

- Refer to "Program 80 – Function Key Descriptor"

CHECK

Options - Program 70

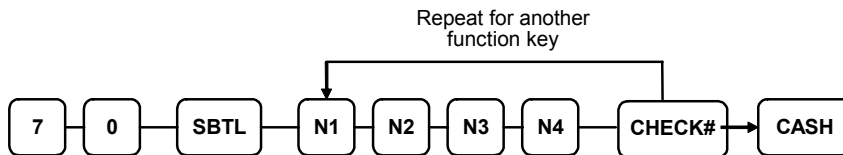

Address	OPTION	VALUE	=	SUM
N1	Key is inactive?	Yes = 1 No = 0		
	Required at Start of Sale?	Yes = 2 No = 0		
	Opening clerk has exclusive access?	Yes = 4 No = 0		
N2	Check track # and balance will print on receipt?	Yes = 0 No = 1		
	Check track # and balance will print on remote?	Yes = 0 No = 2		
	Allow only one check per table?	Yes = 4 No = 0		
N3	Check# is automatically assigned by register?	Yes = 1 No = 0		
	PBAL Key is used as Drive thru recall key?	Yes = 2 No = 0		
N4	Length of Check(0-9)	0-9		

Descriptor

- Refer to "Program 80 – Function Key Descriptor"

CURRENCY CONVERSION

Currency Conversion Rate - Program 90

1. Turn the control lock to the **P** position.
2. To begin the program, enter **9 0**, press the **SBTL** key.

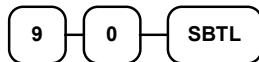

3. Enter the exchange rate of up to 7 digits (do not enter the decimal point), then enter a number from 0 to 7 to indicate the decimal position. See "Currency Exchange Rate Programming Examples" below.

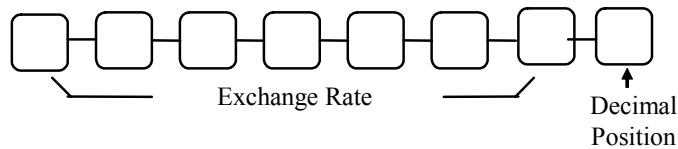

4. Press the function key on the keyboard you wish to program.



5. To program additional function keys, repeat from step 2, or press the **CASH** key to finalize the program.



Currency Exchange Rate Programming Examples

Note: Foreign currency exchange rates may be stated as "foreign currency in dollars", or "dollars in foreign currency". Use the rate stated in "dollars in foreign currency" when you are programming this section.

The US dollar (home currency) is worth 1.3720 Canadian dollars (foreign currency).

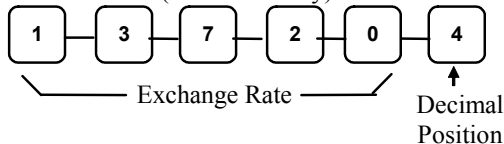

The US dollar (home currency) is worth 110.24 Japanese Yen (foreign currency).

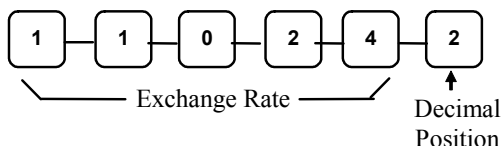

DRIVE THRU / EAT IN / TAKE OUT

Options - Program 70

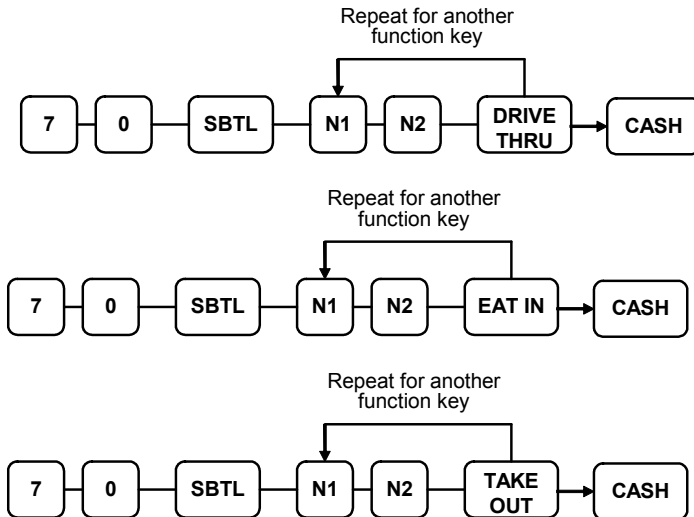

Address	OPTION	VALUE	=	SUM
N1	Exempt tax 1?	Yes = 1 No = 0		
	Exempt tax 2?	Yes = 2 No = 0		
	Exempt tax 3?	Yes = 4 No = 0		
N2	Exempt tax 4?	Yes = 1 No = 0		
	Validation is compulsory?	Yes = 2 No = 0		

Descriptor

- Refer to "Program 80 – Function Key Descriptor"

ERROR CORRECT

Options - Program 70

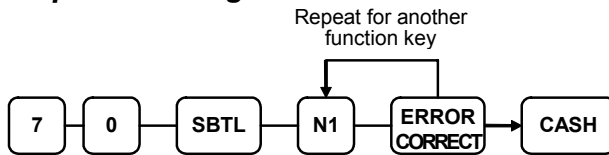

Address	OPTION	VALUE	=	SUM
N1	Key is inactive?	Yes = 1 No = 0		
	Key is active in X control lock position only?	Yes = 2 No = 0		
	Validation is compulsory?	Yes = 4 No = 0		

Descriptor

- Refer to "Program 80 – Function Key Descriptor"

HALO

- Refer to "Program 90 – Function Key HALO"

F/S SUB

Options - Program 70

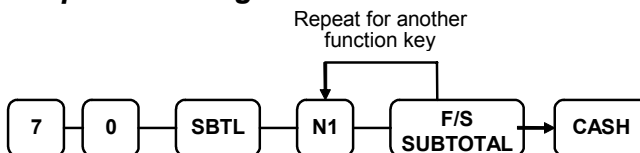

Address	OPTION	VALUE	=	SUM
N1	Key is inactive?	Yes = 1 No = 0		

Descriptor

- Refer to "Program 80 – Function Key Descriptor"

F/S TEND

Options - Program 70

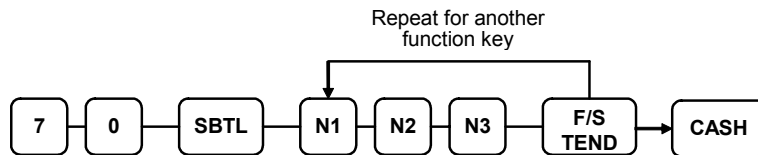

Address	OPTION	VALUE	=	SUM
N1	Exempt tax 1?	Yes = 1 No = 0		
	Exempt tax 2?	Yes = 2 No = 0		
	Exempt tax 3?	Yes = 4 No = 0		
N2	Exempt tax 4?	Yes = 1 No = 0		
	The tender is allowed in any amount?	Yes = 2 No = 0		
	Food stamp change is issued in	Cash = 4 Food stamps = 0		
N3	Open cash drawer?	Yes = 0 No = 1		
	Validation is compulsory?	Yes = 2 No = 0		

Descriptor

- Refer to "Program 80 – Function Key Descriptor"

HALO

- Refer to "Program 90 – Function Key HALO"

GUEST

Options - Program 70

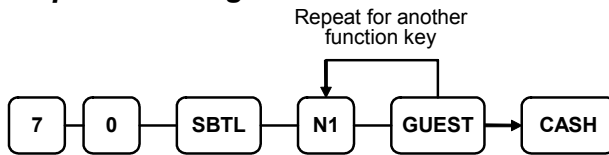

Address	OPTION	VALUE	=	SUM
N1	Required when opening a new check?	Yes = 1 No = 0		
	Before registering, enter a guest number?	Yes = 2 No = 0		
	Print Guest # at the kitchen printer?	Yes = 4 No = 0		

Descriptor

- Refer to "Program 80 – Function Key Descriptor"

LEVEL1-2

Options - Program 70

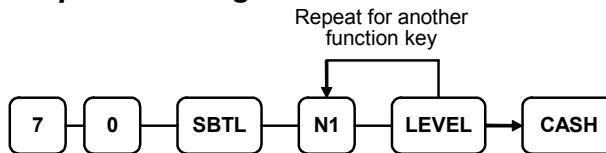

Address	OPTION	VALUE	=	SUM
N1	Print level description at the KP?	Yes = 1 No = 0		

Descriptor

- Refer to "Program 80 – Function Key Descriptor"

#/NS

Options - Program 70

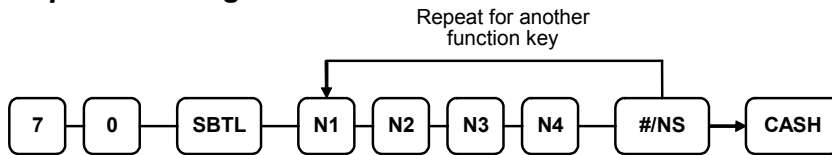

Address	OPTION	VALUE	=	SUM
N1	No Sale is inactive?	Yes = 1 No = 0		
	No Sale active in X control lock position only?	Yes = 2 No = 0		
	No Sale inactive after non-add # entry?	Yes = 4 No = 0		
N2	Enforce non-add # entry at start of sale?	Yes = 1 No = 0		
	Print when a NO SALE is performed?	Yes = 0 No = 2		
	Non-add # entries are prohibited?.	Yes = 4 No = 0		
N3	Compulsory non-add entry must match number of digits set in the MAX DIGIT flag below?	Yes = 1 No = 0		
	Print non-add on guest check?	Yes = 2 No = 0		
N4	Enter maximum number of digits for non-add number entry. Zero(0) means no limit.	0-8		

Descriptor - Programs 80 & 81

Since two distinct functions, # entry and no sale, reside on the same key, different programs are used to program each descriptor. To program the no sale descriptor:

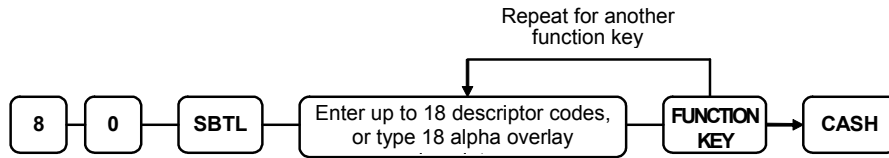

To program the # descriptor

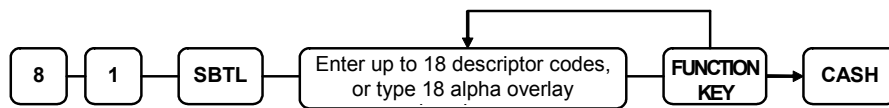

RETURN

Options - Program 70

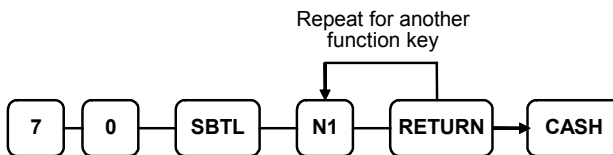

Address	OPTION	VALUE	=	SUM
N1	Key is inactive?	Yes = 1 No = 0		
	Key is active in X control lock position only?	Yes = 2 No = 0		
	Validation is compulsory?	Yes = 4 No = 0		

Descriptor

- Refer to “Program 80 – Function Key Descriptor”

HALO

- Refer to “Program 90 – Function Key HALO”

MODIFIER 1-5

Options - Program 70

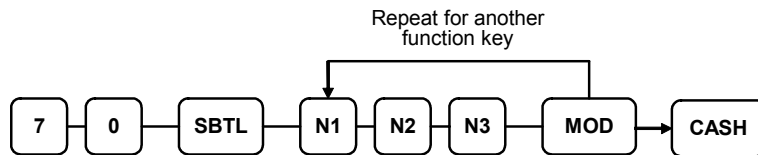

Address	OPTION	VALUE	=	SUM
N1	Key is active in X control lock position only?	Yes = 1 No = 0		
	Modify PLU#?	Yes = 2 No = 0		
N2	Print modifier descriptor on the guest check?	Yes = 1 No = 0		
	Print modifier descriptor on the receipt?	Yes = 2 No = 0		
N3	Value of affected digit(0-9)	0-9		

2. * Affect Digit(1-14) of PLU#

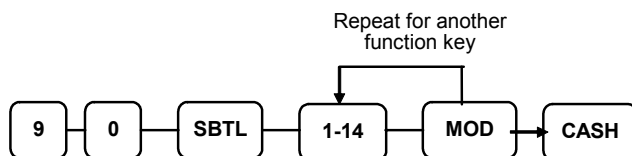

Descriptor

- Refer to "Program 80 – Function Key Descriptor"

PAYMENT

Options - Program 70

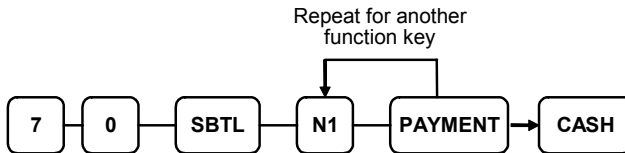

Address	OPTION	VALUE	=	SUM
N1	Require to close check?	Yes = 1 No = 0		

Descriptor

- Refer to "Program 80 – Function Key Descriptor"

PBAL

Options - Program 70

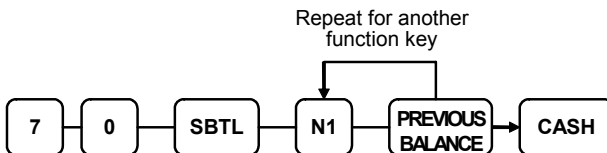

Address	OPTION	VALUE	=	SUM
N1	Previous balance may be entered at any time?	Yes = 1 No = 0		
	Previous balance required at the start of the sale?	Yes = 2 No = 0		

Descriptor

- Refer to "Program 80 – Function Key Descriptor"

PROMO

Options - Program 70

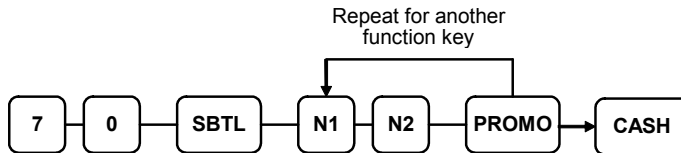

Address	OPTION	VALUE	=	SUM
N1	Key is inactive?	Yes = 1 No = 0		
	Key is active in X control lock position only?	Yes = 2 No = 0		
	Exempt tax 1?	Yes = 4 No = 0		
N2	Exempt tax 2?	Yes = 1 No = 0		
	Exempt tax 3?	Yes = 2 No = 0		
	Exempt tax 4?	Yes = 4 No = 0		

Descriptor

- Refer to "Program 80 – Function Key Descriptor"

PAID OUT1-3

Options - Program 70

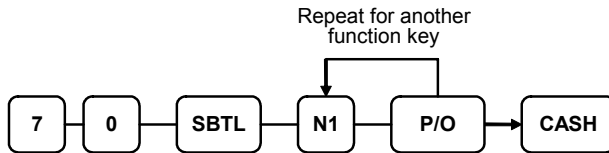

Address	OPTION	VALUE	=	SUM
N1	Key is inactive?	Yes = 1 No = 0		
	Key is active in X control lock position only	Yes = 2 No = 0		
	Validation is compulsory?	Yes = 4 No = 0		

Descriptor

- Refer to "Program 80 – Function Key Descriptor"

PRINT CHECK

Options - Program 70

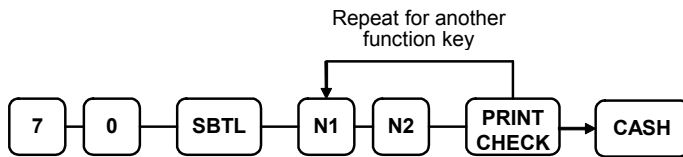

Address	OPTION	VALUE	=	SUM
N1	Enter Port Number. (Zero if the check will print on the receipt printer)	0-2		
N2	Automatically Service Check?	Yes = 1 No = 0		
	Print check transaction on the receipt printer?	Yes = 2 No = 0		
	Skip printing consecutive # on the guest check?	Yes = 4 No = 0		

Descriptor

- Refer to "Program 80 – Function Key Descriptor"

RECD ON ACCT1-3

Options - Program 70

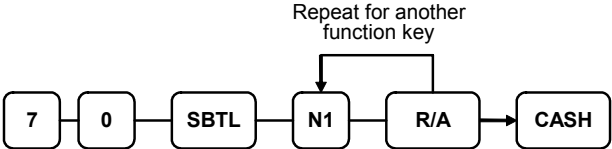

Address	OPTION	VALUE	=	SUM
N1	Key is inactive?	Yes = 1 No = 0		
	Key is active in X control lock position only?	Yes = 2 No = 0		
	Validation is compulsory?	Yes = 4 No = 0		

Descriptor

- Refer to "Program 80 – Function Key Descriptor"

HALO

- Refer to "Program 90 – Function Key HALO"

SCALE

Options - Program 70

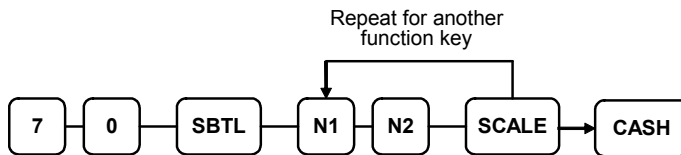

Address	OPTION	VALUE	=	SUM	
N1	Key is inactive?	Yes = 1 No = 0			
	Key is active in X control lock position only?	Yes = 2 No = 0			
	Allow manual entry of weight?	Yes = 4 No = 0			
N2	Subtract tare weight on the scale entry?	Yes = 1 No = 0			
	Weight symbol for manual entry is:	Kg =	2		
		Lb =	0		
	Allow register scaleable items by weight extension or by price entry?	Yes = 4 No = 0			

Descriptor

- Refer to "Program 80 – Function Key Descriptor"

SERVICE

Options - Program 70

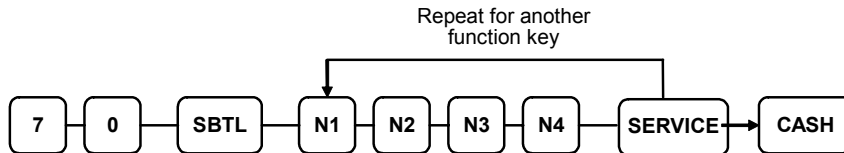

Address	OPTION	VALUE	=	SUM
N1	Compulsory non-add number before this key is used?	Yes = 1 No = 0		
	Print on receipt?	Yes = 0 No = 2		
	Allow negative balance in X control lock position only?	Yes = 4 No = 0		
N2	Calculate tax 1?	Yes = 0 No = 1		
	Calculate tax 2?	Yes = 0 No = 2		
	Calculate tax 3?	Yes = 0 No = 4		
N3	Calculate tax 4?	Yes = 0 No = 1		
	Validation is compulsory?	Yes = 2 No = 0		
N4	Enter the port number if you are using a hard check system.	0-2		

Descriptor

- Refer to "Program 80 – Function Key Descriptor"

SUBTOTAL

Options - Program 70

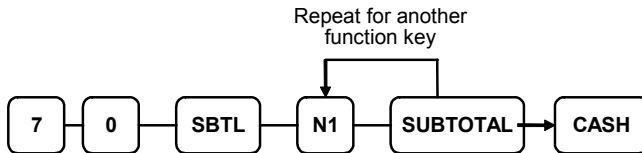

Address	OPTION	VALUE	=	SUM
N1	Key is inactive?	Yes = 1 No = 0		

Descriptor

- Refer to "Program 80 – Function Key Descriptor"

TABLE

Options - Program 70

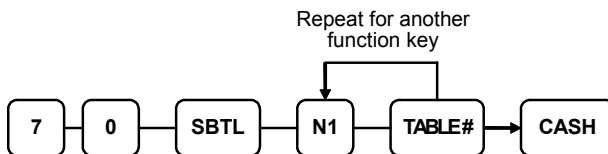

Address	OPTION	VALUE	=	SUM
N1	Table number entry compulsory before opening a new check?	Yes = 1 No = 0		
	Table number entry compulsory for all sales?	Yes = 2 No = 0		
	Print table# at the remote printer?	Yes = 4 No = 0		

Descriptor

- Refer to "Program 80 – Function Key Descriptor"

TARE

Options - Program 70

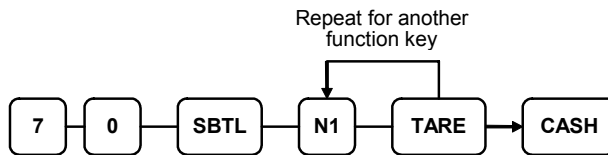

Address	OPTION	VALUE	=	SUM
N1	Key is inactive?	Yes = 1 No = 0		
	Key is active in X control lock position only?	Yes = 2 No = 0		
	Using tare number five to manually enter a tare weight?	Yes = 4 No = 0		

Descriptor

- Refer to "Program 80 – Function Key Descriptor"

TAX EXEMPT

Options - Program 70

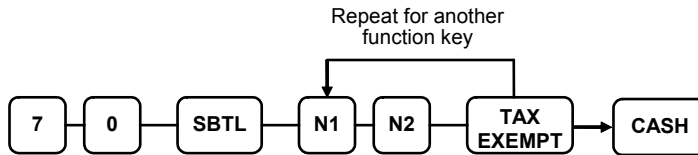

Address	OPTION	VALUE	=	SUM
N1	Exempt tax 1?	Yes = 1 No = 0		
	Exempt tax 2?	Yes = 2 No = 0		
	Exempt tax 3?	Yes = 4 No = 0		
N2	Exempt tax 4?	Yes = 1 No = 0		
	Compulsory non-add number before this key is used?	Yes = 2 No = 0		
	Validation is compulsory?	Yes = 4 No = 0		

Descriptor

- Refer to "Program 80 – Function Key Descriptor"

TIP

Options - Program 70

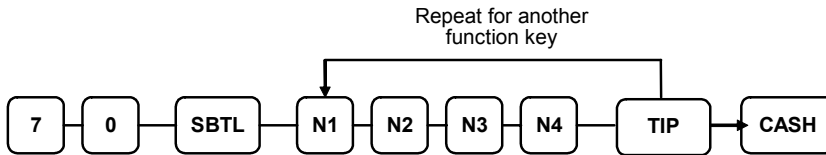

Address	OPTION	VALUE	=	SUM	
N1	Type of tip is:	Percentage =	1		
		Amount =	0		
N2	Key is inactive?	Yes = 1 No = 0			
	Key is active in X control lock position only?	Yes = 2 No = 0			
	Add tax rate 1?	Yes = 4 No = 0			
N3	Add tax rate 2?	Yes = 1 No = 0			
	Add tax rate 3?	Yes = 2 No = 0			
	Add tax rate 4?	Yes = 4 No = 0			
N4	Add the tip total to the NET and GROSS sales total?	Yes = 1 No = 0			

Descriptor

- Refer to "Program 80 – Function Key Descriptor"

VALIDATE

Options - Program 70

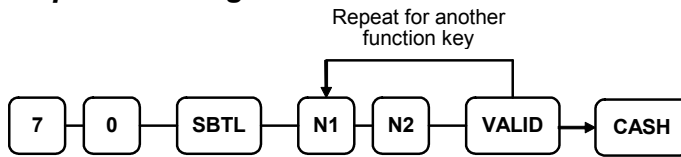

Address	OPTION	VALUE	=	SUM
N1	Enter Port Number.(0-2) Enter Zero if validation is not used.	0-2		
N2	Key is inactive?	Yes = 1 No = 0		
	Allow multiple validation?	Yes = 2 No = 0		

Descriptor

- Refer to "Program 80 – Function Key Descriptor"

VOID

Options - Program 70

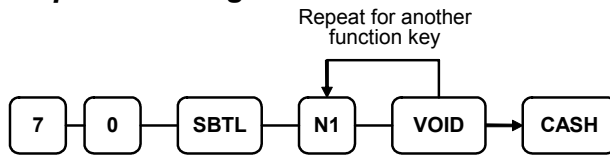

Address	OPTION	VALUE	=	SUM
N1	Key is inactive?	Yes = 1 No = 0		
	Key is active in X control lock position only?	Yes = 2 No = 0		
	Validation is compulsory?	Yes = 4 No = 0		

Descriptor

- Refer to "Program 80 – Function Key Descriptor"

HALO

- Refer to "Program 90 – Function Key HALO"

WASTE

Options - Program 70

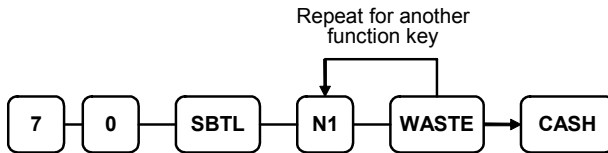

Address	OPTION	VALUE	=	SUM
N1	Key is inactive?	Yes = 1 No = 0		
	Key is active in X control lock position only?	Yes = 2 No = 0		
	Validation is compulsory?	Yes = 4 No = 0		

Descriptor

- Refer to "Program 80 – Function Key Descriptor"

HALO

- Refer to "Program 90 – Function Key HALO"

%1- %5

Options - Program 70

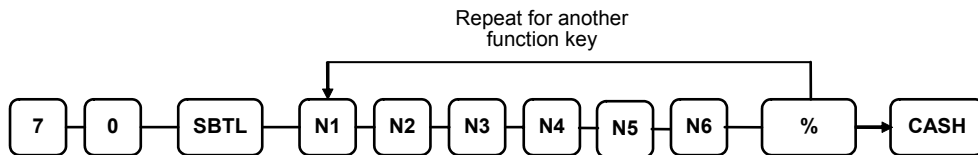

Address	OPTION	VALUE	=	SUM
N1	Apply an:	Amount =	1	
		Percentage =	0	
	Key is inactive?		Yes = 2 No = 0	
	% key is active in X control lock position only?		Yes = 4 No = 0	
N2	% key is:	Open =	1	
		Preset =	0	
	% key is:	Sale =	2	
		Item =	0	
Allow % key override preset?		Yes = 4 No = 0		
N3	% key is:	Positive =	1	
		Negative =	0	
	% amount taxable tax 1?		Yes = 2 No = 0	
N4	% amount taxable tax 2?		Yes = 1 No = 0	
	% amount taxable tax 3?		Yes = 2 No = 0	
	% amount taxable tax 4?		Yes = 4 No = 0	
N5	Reduce(or increase) the food stamp subtotal by % entry?		Yes = 1 No = 0	
	Allow only one time subtotal entry?		Yes = 2 No = 0	
	Allow multiple amount discounts (coupons) without pressing subtotal?		Yes = 4 No = 0	
N6	Allow % key preset override active in X control lock position only?		Yes = 1 No = 0	
	Validation is compulsory?		Yes = 2 No = 0	

Descriptor

- Refer to “Program 80 – Function Key Descriptor”

HALO - Program 90

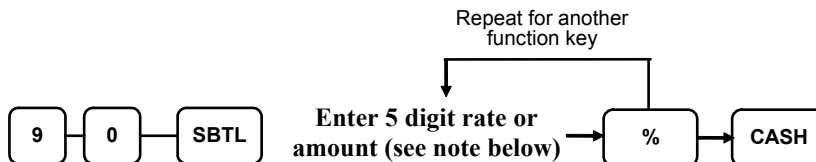

Note: If key is amount , enter 5 digit HALO, or 0 for no HALO. If key is percentage enter the percentage in a five digit format, without the decimal (XX.XXX). For example: for 10%, enter 10000; for 5.55%, enter 05550; for 99.999%, enter 99999.

Clerk Programming

Clerks (which may be used as cashiers), have the following programming options. These options are set through separate programs:

- *Program 800 - Secret Code programming* determines the code that is used for clerk sign on if a code entry sign on method is selected in system option #2 (See "System Option Programming")
- *Program 801 – Drawer Assignment & Training Clerk Programming*
- *Program 810 - Clerk Description Programming* allows you to set a unique, up to 18 character, descriptor for each clerk

Program 800 - Secret Code Programming

1. Turn the control lock to the **P** position.
2. To begin the program, enter **8 0 0**, press the **SBTL** key.

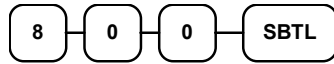

3. Enter the number of the clerk you wish to program; press the **X/TIME** key.



4. Enter a secret code (up to 6 digits); press the **SBTL** key.

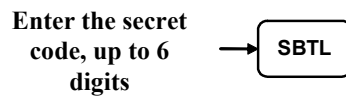

5. Repeat from step 3 for each clerk you wish to program. Press the **CASH** key to finalize the program.

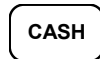

Program 801 - Drawer Assignment & Training Clerk

1. Turn the control lock to the **P** position.
2. To begin the program, enter **8 0 1**, press the **SBTL** key.

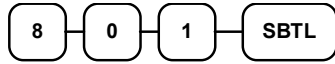

3. Enter the number of the clerk you wish to program; press the **X/TIME** key.

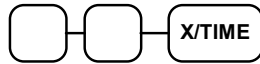

4. Enter an option digit from the table below, press the **SBTL** key.

Address	OPTION	VALUE	=	SUM
N1	Drawer assignment (0: default drawer, 1: second drawer, 2: no drawer)	0-2		
N2	Train Clerk	Yes=1 No=0		



5. Repeat from step 3 for each clerk you wish to program. Press the **CASH** key to finalize the program.



Program 810 – Clerk Description Programming

Program descriptors by typing descriptors on the alpha keyboard overlay or by entering three digit alpha character codes. To describe by three digit alpha character codes you must select 'No' in system option #25(See "System Option Programming").

1. Turn the control lock to the **P** position.
2. To begin the program, enter **8 1 0**, press the **SBTL** key.



3. Enter the number of the clerk you wish to program; press the **X/TIME** key.



4. If you are programming

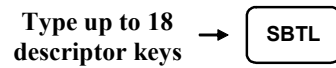

or,

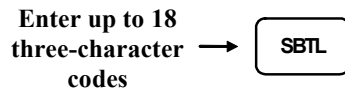

5. Press the **CASH** key to finalize the program.



Mix & Match Programming

Mix & Match Tables have the following programming options. These options are set through separate programs:

- *Program 600 - Trip Level Programming*
- *Program 601 - Price Programming*
- *Program 610 - Mix & Match Description Programming* allows you to set a unique, up to 18character, descriptor for Mix & Match Table.

Program 600 - Trip Level Programming

1. Turn the control lock to the **P** position.
2. To begin the program, enter **6 0 0**, press the **SBTL** key.

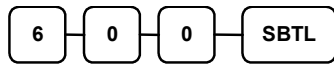

3. Enter the number of the M&M table you wish to program; press the **X/TIME** key.



4. Enter a level of up to 5 digits. (The Maximum Level you can enter is 50000) ; press the **SBTL** key.

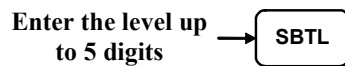

5. Repeat from step 3 for each table you wish to program. Press the **CASH** key to finalize the program.



Program 601 - Price Programming

1. Turn the control lock to the **P** position.
2. To begin the program, enter **6 0 1**, press the **SBTL** key.

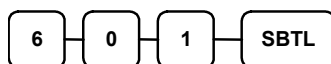

3. Enter the number of the M&M table you wish to program; press the **X/TIME** key.

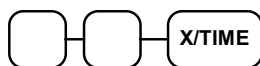

4. Enter a price (up to 7 digits) ; press the **SBTL** key.



5. Repeat from step 3 for each table you wish to program. Press the **CASH** key to finalize the program.

Program 610 - Mix & Match Description Programming

Program descriptors by typing descriptors on the alpha keyboard overlay or by entering three digit alpha character codes. To describe by three digit alpha character codes you must select 'No' in system option #25(See "System Option Programming").

1. Turn the control lock to the **P** position.
2. To begin the program, enter **6 1 0**, press the **SBTL** key.

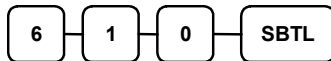

3. Enter the number of the M&M table you wish to program; press the **X/TIME** key.



4. If you are programming

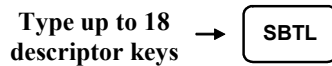

or,

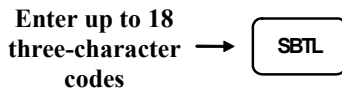

5. Press the **CASH** key to finalize the program.



Group Programming

20 Group totals are available to accumulate totals of individual PLUs that are assigned to each group. Each PLU can be assigned to one, two or three different groups.

- Use program 900 to assign a group status, i.e. a group can be set to *not add* to the total of all groups, or a group can be used to designate like items for kitchen printer assignment.
- Use program 910 to assign a unique descriptor for each group, so that the group may be easily understood on the group report.

Programming Group Status - Program 900

1. Turn the control lock to the **P** position.
2. To begin the program, enter **9 0 0**, press the **SBTL** key.

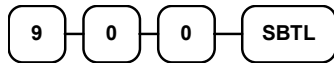

3. Enter the number of the group you wish to program; press the **X/TIME** key.



4. Enter an option digit from the table below, press the **SBTL** key.

Address	OPTION	VALUE	=	SUM
N1	Group total is added to the total of all group on the Group report?	Yes = 0 No = 1		
	Send to kitchen printer ?	Yes = 2 No = 0		
N2	No Choice	0		
	KP PORT# : R(print a kitchen requisition)	1		
	KP PORT# : 1	2		
	KP PORT# : 2	4		
N3	Print RED on KP?	Yes = 1 No = 0		

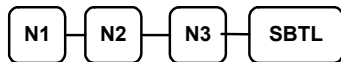

5. To program additional groups, repeat from step 3, or press the **CASH** key to finalize the program.



Programming Group Descriptors

1. Turn the control lock to the **P** position.
2. To begin the program, enter **9 1 0**, press the **SBTL** key.



3. Enter the number of the group you wish to program; press the **X/TIME** key.



4. If you are programming

Type up to 18
descriptor keys → 

or,

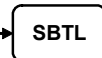
Enter up to 18
three-character
codes → 

5. To program additional groups, repeat from step 3, or press the **CASH** key to finalize the program.



Miscellaneous Programming

Macro Key Sequence Programming

Macros are special function keys that are used to execute a sequence of key depressions. For example, a macro might be used to execute a string of reports or to automatically tender a preset amount. Up to ten different macros may be placed on the keyboard. (See "Function Key Assignment Programming" to place macros on the keyboard.)

To Program a Macro

1. Turn the control lock to the **P** position.
2. To begin the program, enter **1 5 0 0**, press the **SBTL** key.

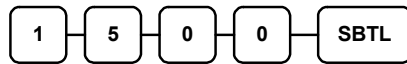

3. Press the **Macro** key that you wish to program.

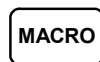

4. First, you must change the Mode Key . Default Mode is PGM Mode.
Therefore, If you want to start in REG Mode, you must change Mode key to REG Mode. Type up to 50 key strokes

Type up to 50 key strokes

5. Turn the control lock to the P position. Press the same **Macro** key to end the sequence



6. Repeat from step 3 - 5 to program additional macros. Press the **CASH** key to finalize the program.



To removing a Macro

If you wish to remove a key stroke from a macro, replace the current function with the INACTIVE function.

Logo Description Programming

Programming the Receipt/Check Endorsement Message

A preamble message of up to six lines can be printed at the top of each receipt; a postamble message of up to six lines can be printed at the bottom of each receipt; an endorsement message of up to ten lines can be printed when a check is endorsed on an optional slip printer. Each line can consist of up to 32 characters.

1. Turn the control lock to the **P** position.
2. To begin the program, enter **7 0 0**, press the **SBTL** key.

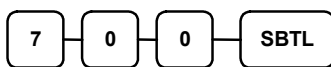

3. Refer to the chart below and enter the number that represents the line you wish to program; press the **X/TIME** key.

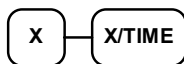

X	Message Line	X	Message Line
1	1 st line of Preamble	12	6 th line of Postamble
2	2 nd line of Preamble	13	1 st line of Endorsement
3	3 rd line of Preamble	14	2 nd line of Endorsement
4	4 th line of Preamble	15	3 rd line of Endorsement
5	5 th line of Preamble	16	4 th line of Endorsement
6	6 th line of Preamble	17	5 th line of Endorsement
7	1 st line of Postamble	18	6 th line of Endorsement
8	2 nd line of Postamble	19	7 th line of Endorsement
9	3 rd line of Postamble	20	8 th line of Endorsement
10	4 th line of Postamble	21	9 th line of Endorsement
11	5 th line of Postamble	22	10 th line of Endorsement

4. If you are programming

Type up to 32 descriptor keys → **SBTL**

or,

Enter up to 32 three-character codes → **SBTL**

5. Press the **CASH** key to finalize the program.



Programming the Financial Report Message

The Financial Report selection allows you to reprogram the descriptors that appear with the Financial Report totals and counters. For example, the first total on the financial report "+PLU TTL" represents the total of all positive PLU entries. You might wish to re-label this total to say "FOOD SALES". You can reprogram any of the Financial Report totals listed here with any 18 character descriptor. (See "Financial Report Message").

1. Turn the control lock to the **P** position.
2. To begin the program, enter **7 0 1**, press the **SBTL** key.

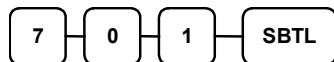

3. Refer to the chart below and enter the number that represents the line you wish to program; press the **X/TIME** key.

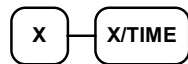

4. If you are programming

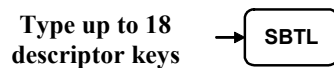

or,

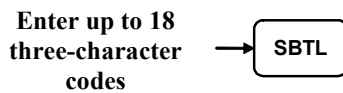

5. Press the **CASH** key to finalize the program.

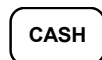

Programming the Clerk Report Message

The Clerk Report selection allows you to reprogram the descriptors that appear with the Clerk Report totals and counters. For example, the first total on the clerk report "NET SALES" might be re-labeled to say "GROSS SALES". You can reprogram any of the Financial Report totals listed here with any 18 character descriptor. (See "Clerk Report Message").

1. Turn the control lock to the **P** position.
2. To begin the program, enter **7 1 0**, press the **SBTL** key.



3. Refer to the chart below and enter the number that represents the line you wish to program; press the **X/TIME** key.

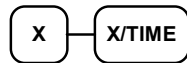

4. If you are programming



or,

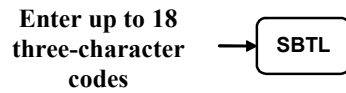

5. Press the **CASH** key to finalize the program.



Programming the Macro Name

Up to ten function locations may be designated as Macro keys. You may wish to program a name for a macro. For example if a macro executes a series of commands to produce daily reports, you can program the descriptor "DAILY", so the macro can easily be identified. Macro names can also be helpful when looking at keyboard layout information with the PC communication utility.

1. Turn the control lock to the **P** position.
2. To begin the program, enter **7 1 1**, press the **SBTL** key.

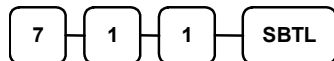

3. Refer to the chart below and enter the number that represents the line you wish to program; press the **X/TIME** key.

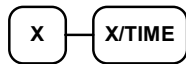

4. If you are programming



or,

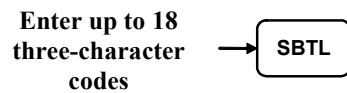

5. Press the **CASH** key to finalize the program.

Financial Report Message

X	Message Line	X	Message Line	X	Message Line
1	+PLU TTL	29	CREDIT TAX4	57	CHG7-IN-D
2	-PLU TTL	30	FD/S CREDIT	58	CHG8-IN-D
3	ADJST TTL	31	RETURN	59	CHG1 SALES
4	NONTAX	32	ERROR CORR	60	CHG2 SALES
5	TAX1 SALES	33	PREVIOUS VD	61	CHG3 SALES
6	TAX2 SALES	34	VOID MODE	62	CHG4 SALES
7	TAX3 SALES	35	CANCEL	63	CHG5 SALES
8	TAX4 SALES	36	GROSS SALES	64	CHG6 SALES
9	TAX1	37	CASH SALES	65	CHG7 SALES
10	TAX2	38	CHECK SALES	66	CHG8 SALES
11	TAX3	39	R/A 1	67	FOREIGN 1
12	TAX4	40	R/A 2	68	FOREIGN 2
13	XMPT1 SALES	41	R/A 3	69	FOREIGN 3
14	XMPT2 SALES	42	P/O 1	70	FOREIGN 4
15	XMPT3 SALES	43	P/O 2	71	DRWR TTL
16	XMPT4 SALES	44	P/O 3	72	PROMO
17	EATIN TTL	45	HASH TTL	73	WASTE
18	TAKEOUT TTL	46	AUDACTION	74	TIP
19	DRTHRU TTL	47	NOSALE	75	TRAIN TTL
20	% 1	48	CASH-IN-D	76	BAL FORWARD
21	% 2	49	CHECK-IN-D	77	GUESTS
22	% 3	50	FD/S-IN-D	78	P/BAL
23	% 4	51	CHG1-IN-D	79	CHECKS PAID
24	% 5	52	CHG2-IN-D	80	SERVICE
25	NET SALE	53	CHG3-IN-D	81	MIX&MATCH
26	CREDIT TAX1	54	CHG4-IN-D	82	ROUND TTL
27	CREDIT TAX2	55	CHG5-IN-D		
28	CREDIT TAX3	56	CHG6-IN-D		

e

Clerk Report Message

X	Message Line	X	Message Line	X	Message Line
1	NET SALE	24	CREDIT TAX2	47	CHG2 SALES
2	NONTAX	25	CREDIT TAX3	48	CHG3 SALES
3	TAX1 SALES	26	CREDIT TAX4	49	CHG4 SALES
4	TAX2 SALES	27	FD/S CREDIT	50	CHG5 SALES
5	TAX3 SALES	28	RETURN	51	CHG6 SALES
6	TAX4 SALES	29	ERROR CORR	52	CHG7 SALES
7	TAX1	30	PREVIOUS VD	53	CHG8 SALES
8	TAX2	31	VOID MODE	54	FOREIGN 1
9	TAX3	32	CANCEL	55	FOREIGN 2
10	TAX4	33	GROSS SALES	56	FOREIGN 3
11	XMPT1 SALES	34	CASH SALES	57	FOREIGN 4
12	XMPT2 SALES	35	CHECK SALES	58	DRWR TTL
13	XMPT3 SALES	36	R/A 1	59	PROMO
14	XMPT4 SALES	37	R/A 2	60	WASTE
15	EATIN TTL	38	R/A 3	61	TIP
16	TAKEOUT TTL	39	P/O 1	62	TRAIN TTL
17	DRTHRU TTL	40	P/O 2	63	BAL FORWARD
18	% 1	41	P/O 3	64	GUESTS
19	% 2	42	HASH TTL	65	P/BAL
20	% 3	43	CASH-IN-D	66	CHECKS PAID
21	% 4	44	CHECK-IN-D	67	SERVICE
22	% 5	45	FD/S-IN-D	68	NOSALE
23	CREDIT TAX1	46	CHG1 SALES	69	MIX&MATCH

NLU Code Number Programming

NLU are fixed keys on the keyboard (like traditional department keys) that access specific PLUs. On the default keyboard, there are 117 NLU keys and the PLU# assigned to the NLU key is the same, i.e. NLU key number one is PLU #1. However, with this program, you can assign any PLU number you wish to any one of the 117 possible NLU keys.

Programming the NLU Code Number

1. Turn the control lock to the **P** position.
2. To begin the program, enter **1 0 0 0**, press the **SBTL** key.

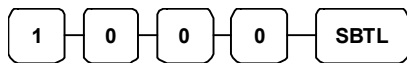

3. Type the new PLU code number you wish to use for this NLU key, and Press the NLU key on the keyboard you wish to program, and Press the NLU key again.

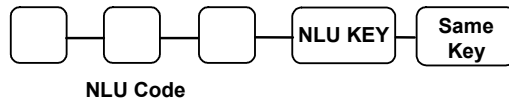

4. Press **CASH** to finalize the program



Cash-In-Drawer Limit Programming

You can set a limit for cash in drawer. When cash in drawer exceeds the limit you program here, a warning will display on the screen. You must press CLEAR to remove the warning and continue operations. The warning will continue to appear at the completion of every transaction with the limit exceeded, until you use the PAID OUT function to remove cash from the drawer.

Programming the Drawer Limit

1. Turn the control lock to the **P** position.
2. To begin the program, enter **1 1 0 0**, press the **SBTL** key.

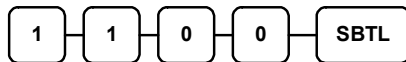

3. Enter a cash-in-drawer limit (up to 8 digits or **0** for no limit); press the **X/TIME** key.

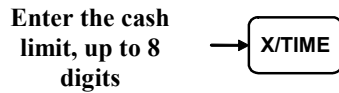

4. Press the **CASH** key to finalize the program.



Check Change Limit Programming

Use this program to set the maximum amount of cash that can be returned when a check is tendered for an amount greater than the amount of the sale. For example, if the check change limit is € 10.00 the maximum amount that can be tendered into the check key on a € 5.00 sale is € 15.00.

Programming the Check Change Limit

1. Turn the control lock to the **P** position.
2. To begin the program, enter **1 2 0 0**, press the **SBTL** key.

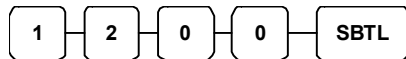

3. Enter a cash-in-drawer limit (up to 8 digits or **0** for no limit); press the **X/TIME** key.

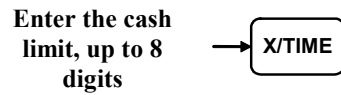

4. Press the **CASH** key to finalize the program.



Date and Time Programming

Use this program to set the clock and calendar on your ER5200/5240/5215. The date changes automatically. After initial setting, time changing will probably be required only for beginning and ending daylight savings time.

Programming the Date and Time

1. Turn the control lock to the **P** position.
2. To begin the program, enter **1 3 0 0**, press the **SBTL** key.

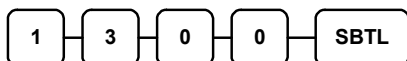

3. Enter time in military standard time (based on 24 hours), must be four digits (i.e. 1300 hours = 1:00 PM); press the **X/TIME** key.



4. Enter the date in MM(month) DD(day) and YY(year) format. Press the **X/TIME** key:



5. Press the **CASH** key to finalize the program.



Scale Tare Weight Programming

A tare is the amount of weight representing the container, or package when items are sold by weight. You can pre-program five tare weights, representing the weight of different containers. When you place an item and a container on optional scale, you can enter the tare number to automatically subtract the pre-programmed tare weight. If you choose to use tare #5 for manual tare weight entry, do not enter a weight for tare #5. (See TARE .)

1. Turn the control lock to the **P** position.
2. To begin the program, enter **1 4 0 0**, press the **SBTL** key.

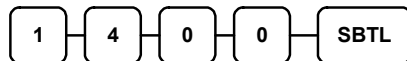

3. Enter the number (**1-5**) of the tare you wish to program; press the **X/TIME** key.

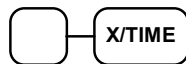

4. Enter the weight of the tare (one digit preceding the decimal key, the decimal key, then three digits after the decimal key). Press the **SBTL** key.



5. To program additional tare weights, repeat from step 3, or press the **CASH** key to finalize the program.



Machine Number Programming

The machine number is printed on the register receipt. Program a machine number so that any receipt can be identified with the store or register where the transaction took place.

Programming the Machine Number

1. Turn the control lock to the **P** position.
2. To begin the program, enter **1 6 0 0**, press the **SBTL** key.

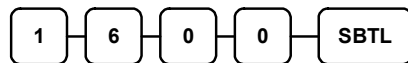

3. Enter a machine number (up to 5 digits); press the **X/TIME** key.



4. Press the **CASH** key to finalize the program.

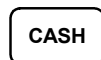

Program Scans

Since much time and energy has been invested in the planning and programming of your *ER-5200/5240/5215*, it is advisable to print a hard copy of the final program for future reference. This copy should be kept in a safe place.

1. Turn the control lock to the **P** position.
2. To print a program scan, enter **1 5**, press the **SBTL** key.



3. In this step, there are three different ways to scan program information. One is PLU, the other is Macro, The third is Others.

PLU PROGRAM SCAN

To read one PLU program information, enter the number (1-1000) of the PLU and press the same number and **PLU** key.

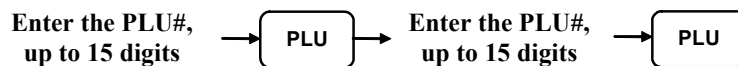

Press a PLU key on the keyboard and press same key again.



To read multiple PLU program information, enter the first number (1-1000) and press **PLU** key. Press the last number (1-1000) and press **PLU** key

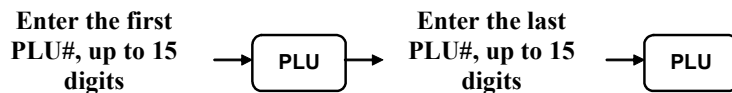

Press a PLU key on the keyboard .



MACRO PROGRAM SCAN

To read MACRO information, press the MACRO key to be scanned,



Refer to the chart below and enter a digit to represent the segment of the program you wish to print; press the **X/TIME** key. To program additional scan, repeat this operation.

OTHERS PROGRAM SCAN

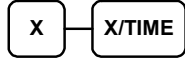

X	Program	X	Program
0	Group	9	Financial Report message
1	Tax	10	Clerk Report message
2	System option	11	Macro Name
3	Print option	12	Drawer Limit
4	Function keys	13	Check Change Limit
5	Clerk	14	Time & Date
6	Preamble message	15	Tare Weight
7	Postamble message	16	Machine Number
8	Endorsement message	17	Mix & Match

4. Press the **CASH** key to finalize the program.

